

Ersatzteilliste

Spare parts list

Liste de pièces de rechange

Lista de piezas de recambio

Listino per pezzi di ricambio

Hako

Hakorette 5008

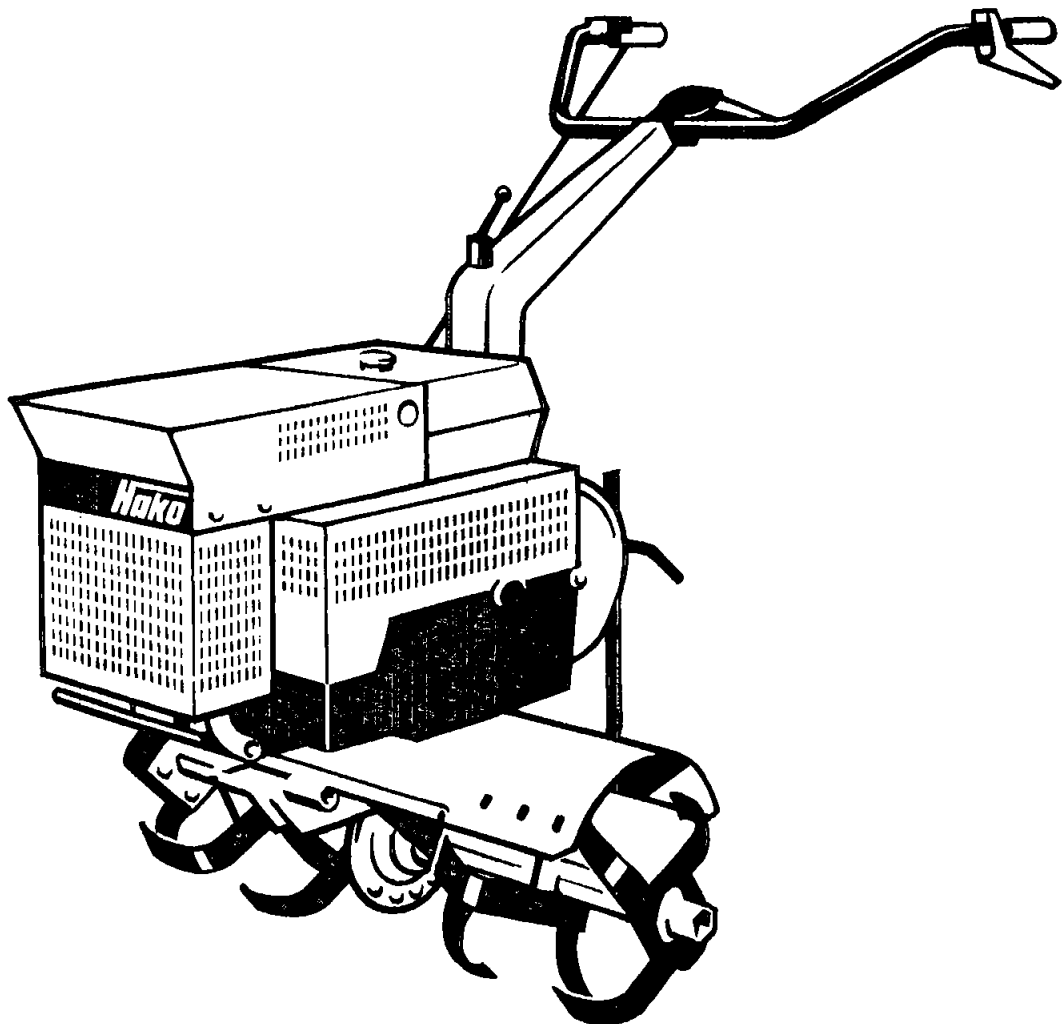

Bestellen Sie Ersatzteile grundsätzlich bei Ihrem Werkstützpunkt und machen Sie folgende Angaben:

1. Gerätetype, Motor- und Gerätenummer.
2. Genaue Bezeichnung des gewünschten Teiles sowie **Bestell- und Lagernummer**. Keine Bildnummer angeben.
3. Art des Versandes: z. B. Post, Fracht oder Expreß.
4. Genaue Anschrift mit Postleitzahl; bei Bahnversand Stationsbezeichnung.
5. In Zweifelsfällen Muster einsenden, Lieferschein oder Begleitschreiben beigeben.
6. Rückgabe der Musterteile erfolgt nur, wenn ausdrücklich verlangt.

Verwenden Sie nur Original-Ersatzteile!

INHALT

	Seite
Kurbelgehäuse, Zylinder, Lüftung, Reversierstarter	2 – 5
Bing-Drosselklappen-Vergaser 8/25 S 126, Zundanlage, Drehzahlbegrenzer	6 – 9
Motorzubehör	10 – 11
Getriebe	12 – 13
Hakomatic-Verstelltrieb	14 – 15
Motorkonsole, Seitenwand, Tragbogen, Bremsporn, Vorstecker, Schilder, Aufkleber	16 – 19
Holm, Schalthebel, Spannrollenhebel, Hakomatic-Verstellhebel, Schaltung	20 – 23

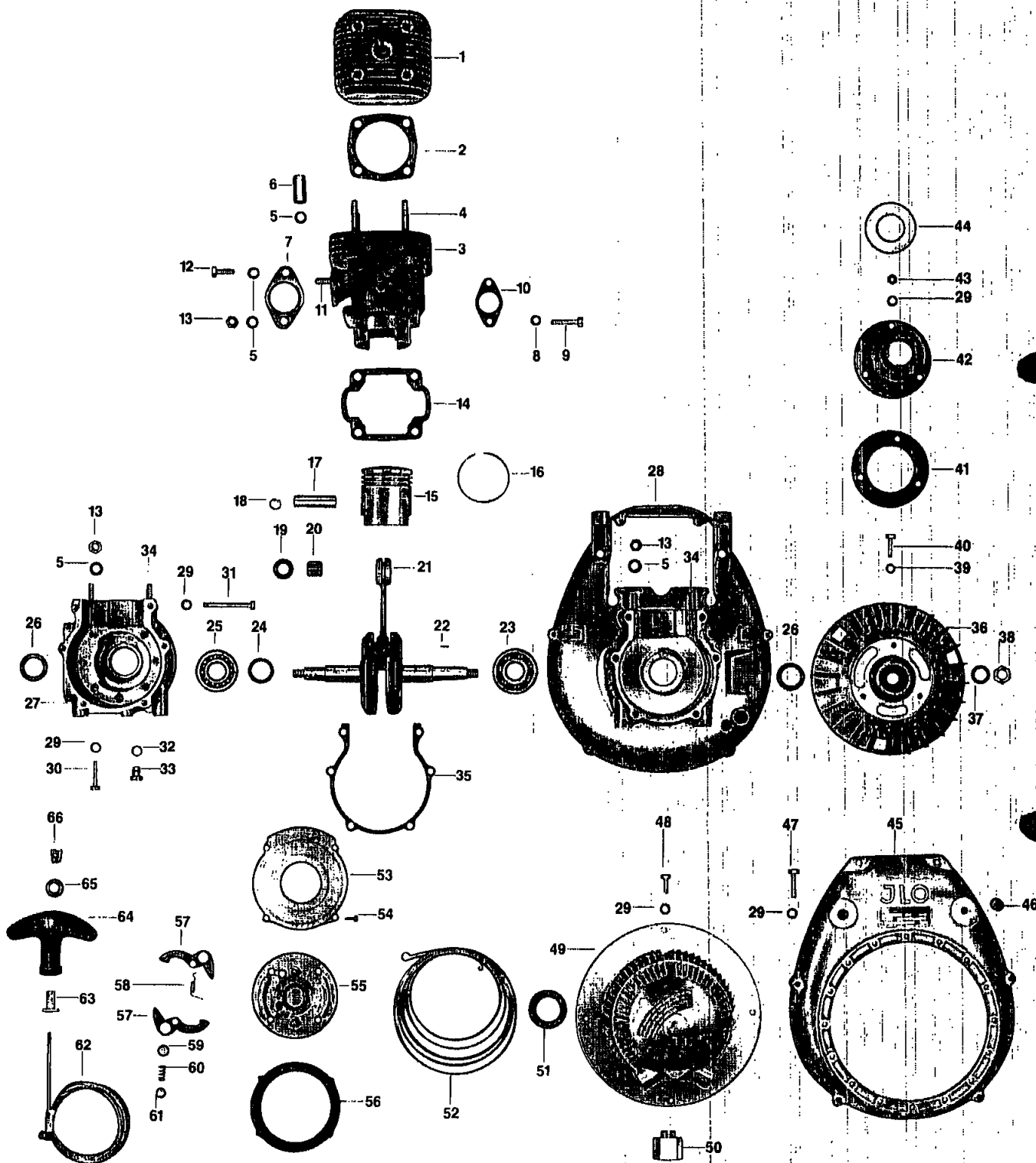

**Kurbelgehäuse, Zylinder, Lüftung, Reversierstarter
für JLO-Motor L 152 90-05790-3**

Bild-Nr.	Anz.	Teilbezeichnung	Sachnummer	Bestell- u Lager-Nr.
1	1	Zylinderkopf	152.07-119-01	43-020
2	1	Dichtung	152.07-729-00	02-103
3	1	Zylinder	152.07-801-20	43-019
4	4	Stiftschraube M 8 x 40 DIN 939	000.41-230-52	05-403
5	8	Federring B 8 DIN 127	12505-05-3	05-341
6	4	Langmutter	152 07-469-10	15-317
7	1	Dichtung	102 07-749-00	02-426
8	2	Federring B 6 DIN 127	12505-04-6	05-340
9	2	Schraube M 6 x 20 DIN 933	11038-09-8	05-302
10	1	Dichtung	102 07-739-00	02-104
11	1	Stiftschraube M 8 x 20 DIN 939	0012 7640	12-764
12	1	Schraube M 8 x 20 DIN 933	11038-21-3	05-309
13	1	Mutter M 8 DIN 934	12022-05-9	05-335
14	1	Dichtung	152.07-719-10	02-105
15	1	Kolben 59,0 \varnothing	152 05-900-00	41-020
	1	Kolben 59,5 \varnothing	152 98-950-00	41-021
	1	Kolben 60,0 \varnothing	152 98-960-00	41-019
16	3	Kolbenring 59,0 x 2,5	000 42-124-15	02-102
	3	Kolbenring 59,5 x 2,5	000 42-124-20	02-248
	3	Kolbenring 60,0 x 2,5	000 42-124-25	02-259
17	1	Kolbenbolzen	152 05-219-00	02-260
18	2	Sicherung	000.40-610-14	05-117
19	2	Anlaufscheibe	152 03-065-00	04-292
20	1	Nadellager	000 39-107-20	04-293
21	1	Kurbelwelle m. Zapfen 16 ^{er} mm	152 86-901-11	42-017
22	1	Zylinderrolle	152.03-649-10	02-328
23	1	Lager 6304 DIN 625	000 39-073-40	05-238
24	1	Distanzscheibe	152 03-625-00	04-294
25	1	Lager 6204 DIN 625	000.39-073-20	05-227
26	2	Dichtring A 20 x 32 x 7/8	000 42-313-04	05-115
27	1	Kurbelgehäusedeckel	152.01-036-10	28-109
28	1	Kurbelgehäuse	152 01-051-00	28-112
29	6	Federring B 6 DIN 127	12505-04-6	05-340
30	4	Schraube M 6 x 30 DIN 84	000.41-501-42	05-356
31	2	Schraube M 6 x 55 DIN 84	000 41-501-47	02-406
32	1	Dichtring A 8 x 14 DIN 7603	000 35-001-00	15-409
33	1	Schraube M 8 x 10 DIN 933	00022500	02-250
34	4	Stiftschraube M 8 x 22 DIN 835	000 41-270-89	05-139
35	1	Dichtung Lüfterrad 16 ^{er} mm Bohrung	152.01-719-00	43-023
36	1	Schäufelrad	152.14-071-30	28-110
37	2	Federring B 12 DIN 127	12505-07-9	05-343
38	2	Mutter M 12 x 1,5 DIN 936	000.41-951-03	15-410
39	3	Scheibe A 6,4 DIN 6798	0005 4180	05-418
Zu 21	1	Kurbelwelle m. Zapfen 26 ^{er} mm		66-042
Zu 36	1	Lüfterrad 20 ^{er} mm - 3 Bohrung		66-045

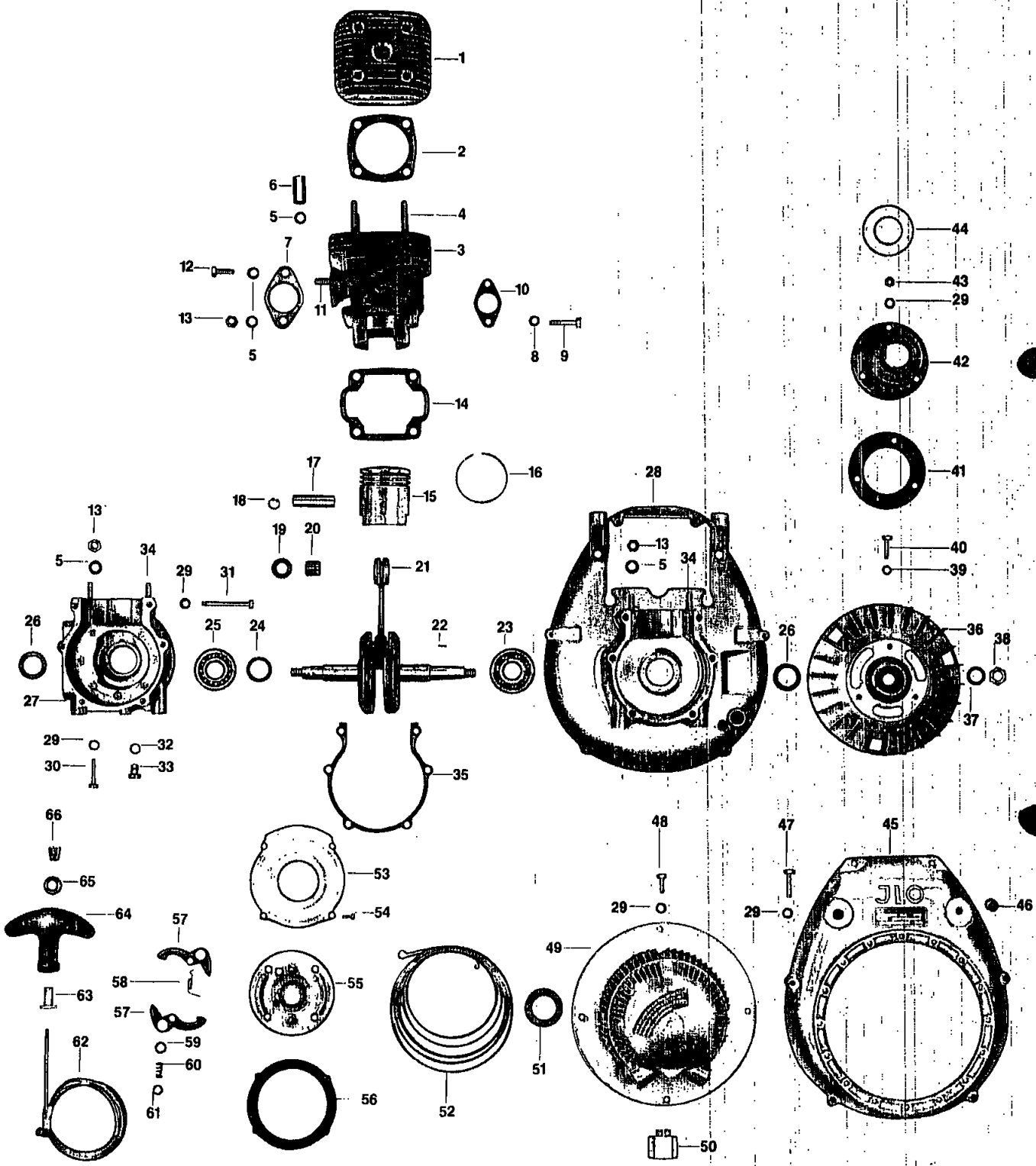

**Kurbelgehäuse, Zylinder, Lüftung, Reversierstarter
für JLO-Motor L 152 90-05780-3**

Bild-Nr.	Anz.	Teilbezeichnung	Sachnummer	Bestell- u Lager-Nr
40	3	Schraube M 6 x 22 DIN 933	11038-10-6	15-- 407
41	1	Dichtung	102 41-729-00	02-407
42	1	Mitnehmer	102 41-849-00	10-515
43	3	Mutter M 6 DIN 934	12022-04-2	05-333
44	1	Staubdichtring	102.41-719-00	11-012
45	1	Gebleasedeckel	152 14-019-01	43-022
46	2	Verschlußstopfen	002 44-427-90	02-331
47	4	Schraube M 6 x 25 DIN 933	11038-12-2	05-304
		Reversierstarter		
48	4	Schraube M 6 x 18 DIN 933	11038-08-0	15-421
49	1	Startergehäuse	152.41-011-30	19-069
	1	Startergehäuse kpl.	152.41-821-01	19-064
50	1	Seilführungsbuchse	102 41-469-00	13-222
51	1	Scheibe	102.41-529-00	13--237
52	1	Rückholfeder	102 41-449-11	19-072
53	1	Abdeckblech	102 41-149-00	13-235
54	4	Kerbschraube M 4 x 10	000 41-617-89	13-236
55	1	Seilscheibe	102.41-121-11	19-070
56	1	Zwischenblech	102 41-139-01	13-229
57	2	Starterklinke	102 41-219-01	13-233
58	2	Haltefeder	102.41-529-00	13-234
59	2	äußere Federkappe	102 41-519-00	13-232
60	2	Bremsfeder	102 41-509-00	13-231
61	2	innere Federkappe	102.41-499-00	13-- 230
62	1	Zugseil	102 41-829-00	19-002
63	1	Verstärkungshülse	252 41-009-00	04-295
64	1	Handgriff kpl.	102 41-801-00	28 --111
65	1	Haltering	252.41-015-00	04-296
66	1	Haltekeil	252 41-016-00	04-391
		Reparatursätze L 152		
	1	Reparatur-Zzylindersatz (Zylinder, Kolben, Dichtungen 59,5 (1))	152.92-905-20	41-025
	1	Satz Dichtungen	—	43--015
	1	Rumpfmotor <i>16% Zylinder</i>	152 00-0002-03	27-012
	1	Motor mit Zündanlage und Lufferrad, ohne Vergaser, Auspuff, Rev-Starter	90-05780-3	35-013
	1	<i>Abziehvorrichtung</i>		<i>68-042</i>
	1	<i>Rumpfmotor 20% Zylinder</i>	<i>152 60002 100</i>	

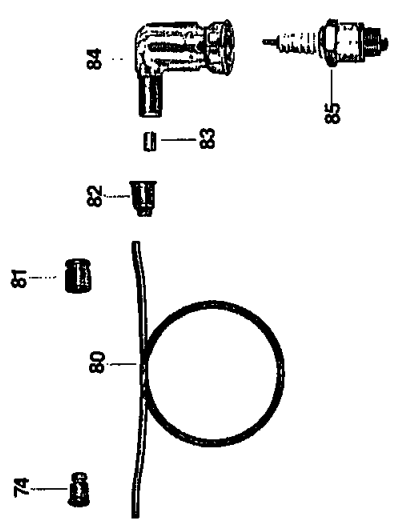
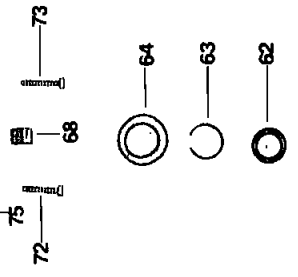
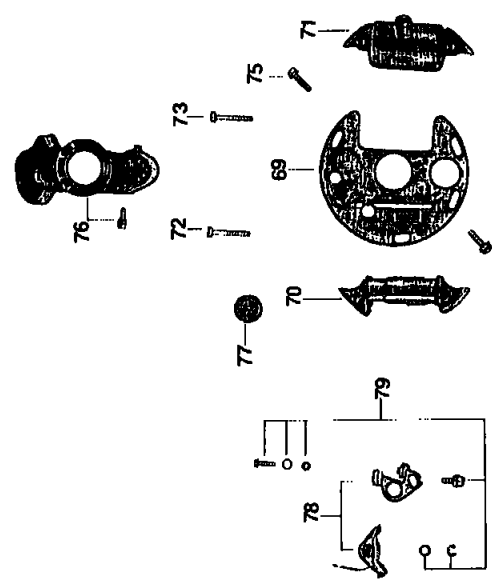
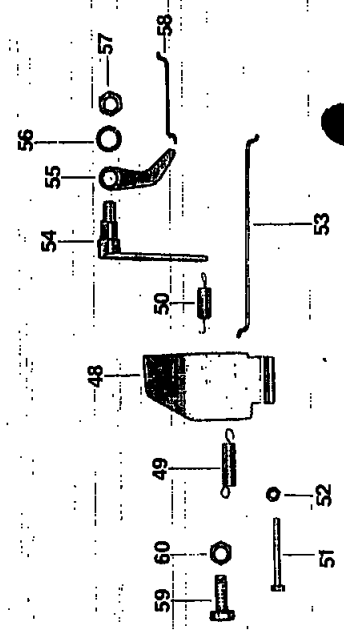
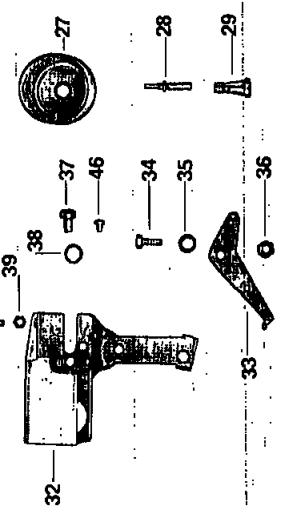
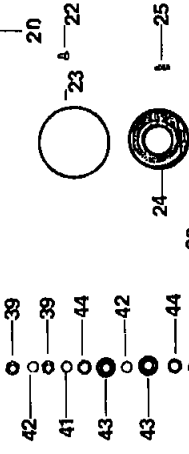
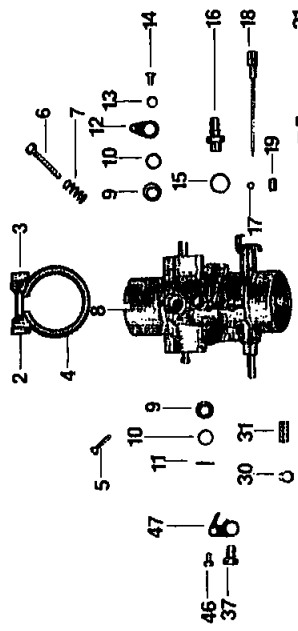

Bing-Drosselklappen-Vergaser 8/25 S 126
Zündanlage, Drehzahlbegrenzer

Bild-Nr.	Anz.	Teilbezeichnung	Sachnummer	Bestell- u Lager-Nr
Vergaser mit Einhebelbedienung				
1	1	Vergaserstutzen	335.07-024-0	53--403
	1	Kerbstift 2,5 x 10	000 4030-227	53--404
2	1	Mutter	42-611	02-470
3	1	Klemmschraube	40-626	53-278
4	1	Klemmring	59-080	53-277
5	1	Zapfenschraube	40-310	53-402
6	1	Stellschraube	40-440	53-279
7	1	Feder	60-080	53-405
8	1	Vergaser	8/25 S 126	29--122
9	2	Dichthülse	65-545	53-282
10	2	Scheibe	56-095	53-281
11	1	Paßkerbstift	52-048	53-280
12	1	Drosselhebel	58-190	53-406
13	1	Federring	61-672	53-284
14	1	Linsenschraube	40-306	53-285
15	1	Dichtring	65-121	15-224
16	1	Schlauchtülle	51-330	53-407
17	1	Dichtring	65-050	02-442
18	1	Leerlaufdüse Nr 70	44-308.70	53-408
19	1	Gewindestift	50-321	02-443
20	1	Feder	60-075	53-289
21	1	Luftregulierschraube	50-013	53-290
22	1	Korrekturdüse Nr. 70	44-021/70	07-706
23	1	Dichtring	65-452	04-121
24	1	Schwimmer	35-217	04-122
25	1	Schwimmernadel	47-056	04-124
26	1	Stift	52-055	53-291
27	1	Schwimmerkappe	30-540	53-292
28	1	Mischrohr Nr 3	45-350	53-293
29	1	Hauptdüse Nr. 130	44-915/130	53-409
30	1	Sicherung	61-623	53-410
31	1	Drehfeder	61-081	53-411
32	1	Konsole	315.19-004-01	21-057
	1	Schelle für Bowdenzug	315.19-006-00	53-419
	1	Schraube M 5 x 12 DIN 933	11038-03-1	15-280
	1	Federring B 5 DIN 127	12505-03-8	50-417
33	1	Schwenkhebel	315 19-011-00	07-701
34	1	Schraube M 5 x 12 DIN 933	11038-03-1	15-280
35	1	Scheibe 5,3 DIN 125	12310-02-5	07-466
36	1	Mutter M 5 DIN 934	12022-03-4	05-335
37	2	Schraube M 6 x 10 DIN 84	000.4150-134	07-708
38	1	Federring B 6 DIN 127	12505-04-6	05-340
39	3	Mutter M 4 DIN 934	12022-02-6	05-281
40	1	Stiftschraube M 4 x 15 DIN 835	000 4127-014	05-525
41	1	Federring B 4 DIN 127	12505-02-0	15-424
42	2	Scheibe 4,3 DIN 125	12310-01-7	05-371
43	2	Isolierscheibe	315 11-007-00	05-522
44	2	Isolierscheibe	315.11-006-00	05-521
45	1	Tupfer	48-926	07 703

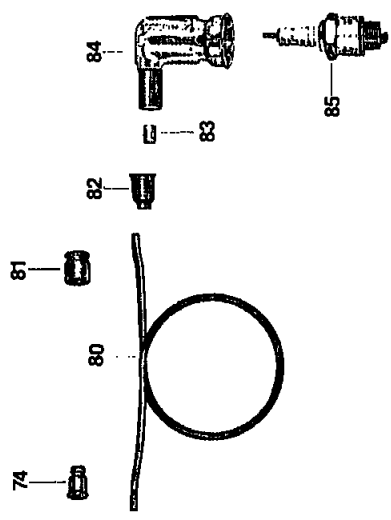
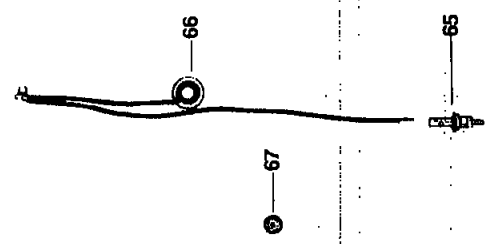
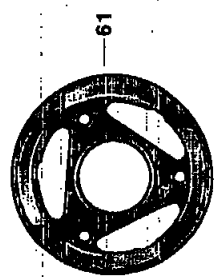
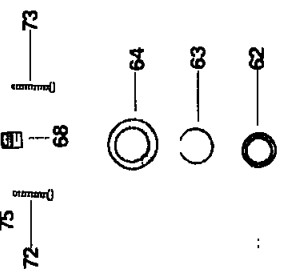
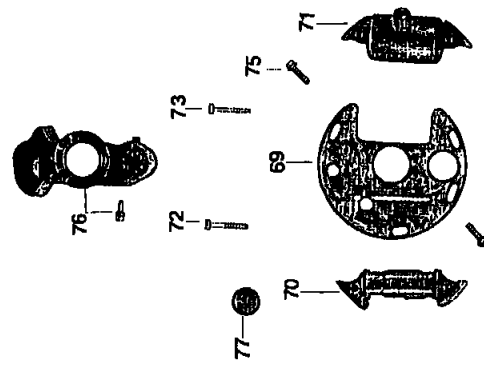
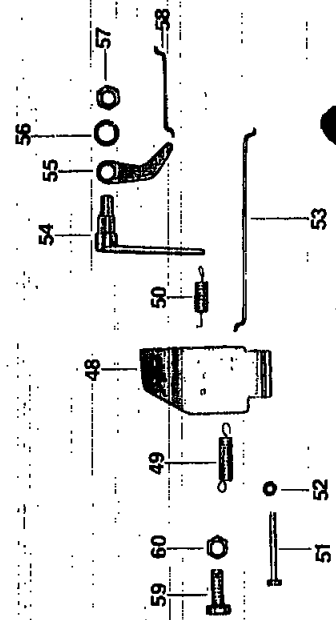
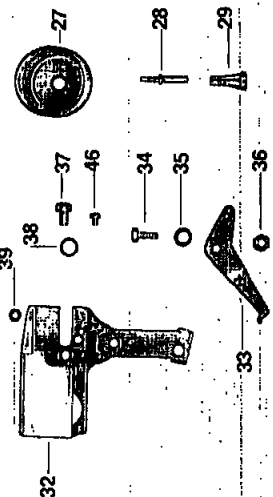
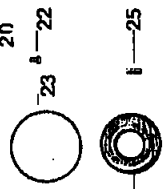
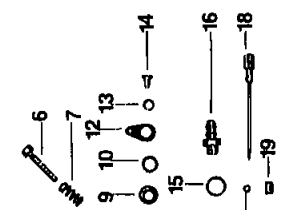
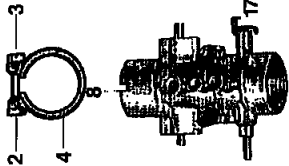

Bing-Drosselklappen-Vergaser 8/25 S 126
Zündanlage, Drehzahlbegrenzer

Bild-Nr	Anz	Teilbezeichnung	Sachnummer	Bestell- u Lager-Nr
	1	Tupferfeder	60-023	07-707
	1	Splint	49-020	04-120
46	2	Schraube M 3,5 x 5 DIN 84	000.41-50-077	53-412
47	1	Halteplättchen	57-194	53-413
		Drehzahlbegrenzer		
48	1	Windfahne	152 15-803-00	04- 393
49	1	Zugfeder	035.15-112-01	05-531
50	1	Zugfeder	152 15-109-00	53-414
51	1	Schraube M 5 x 40 DIN 933	000 41-010-52	05-527
52	1	Mutter M 5 DIN 934	12022-03-4	05-332
53	1	Windfahngestänge	152.15-169-02	53-415
54	1	Mitnehmerwelle	315 15-806-00	05-528
55	1	Steuerhebel	152 15-299-00	53-416
56	1	Federring B 8 DIN 127	12505-05-3	05-341
57	1	Mutter M 8 DIN 439	12012-01-9	04-560
58	1	Steuerdraht kurz	152.15-289-00	53-417
59	1	Halteflasche	000.4101-492	53-418
60	1	Mutter M 8 DIN 934	12022-05-9	05-335
		Zündanlage		
61	1	Polrad	1 215 254 318	42-016
62	1	Nocken	1 212 202 040	53-393
63	1	Spannring	102.03-659-00	02-266
64	1	Filzring	000.35-010-04	53-394
65	1	Anschlußschraube	102 11-819-00	02-313 05-577
66	1	Kondensator	1 237 330 035	07-352
67	1	Kabeldurchführung	002 44-426-90	15-426
68	1	Schmierfilz	2 201 005 007	07-554
69	1	Ankerplatte kpl.	MZ 9/10465	29-040
70	1	Lichtspule	1 214 210 042	07-557
71	1	Zündspule	2 204 211 030	07-544
72	2	Schraube	1 213-410-051	53-395
73	2	Schraube	1 213-410-052	53-396
74	1	Schutzkappe	2 200-522-001	02-347
75	1	Schraube M 4 x 18 DIN 84	000 41-500-99	15-423
76	1	Staubschutzkapsel mit Schraube	002.44-090-90	29-024
77	1	Kabeldurchführung	002 44-435-90	15-427
78	1	Kontaktsatz	2 207 013 001	29-128
79	1	Befestigungsteilesatz	1 217-010-000	53-401
80	1	Zündleitung	6.181-190-100	10-514
81	1	Kabeldurchführung	002.44-401-90	02-332
82	1	Gummitülle	1 230 522 007	12-621
83	1	Reduzierhülse	1 299 999 002	02-128
84	1	Entstörkappe	0 356 351 007	08-047
85	1	Zündkerze	M 175 T 1	06-020

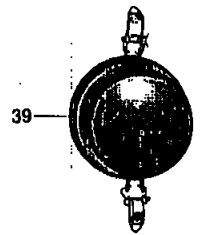
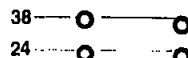
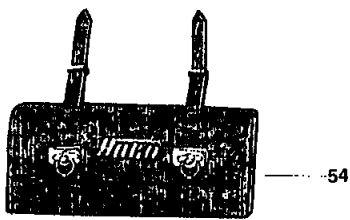
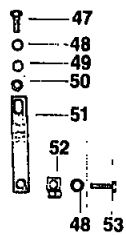
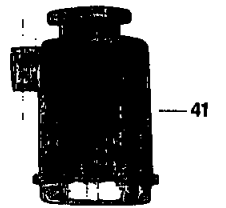
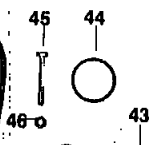
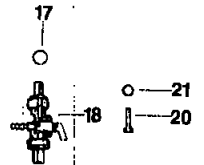
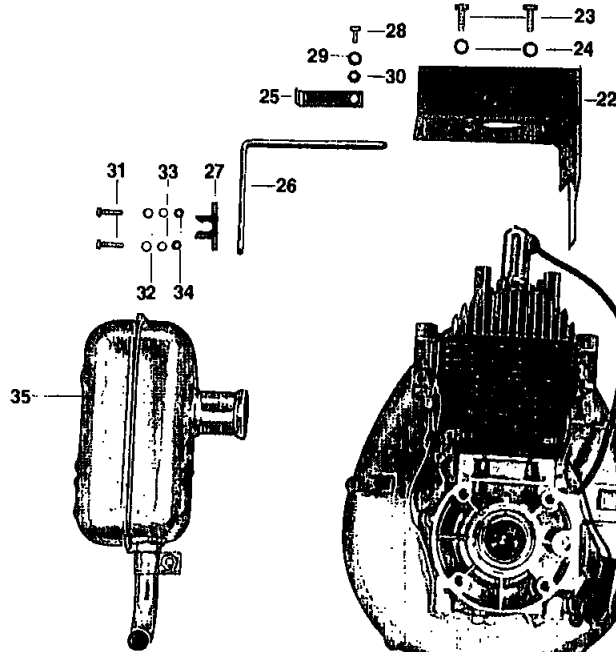
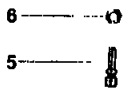
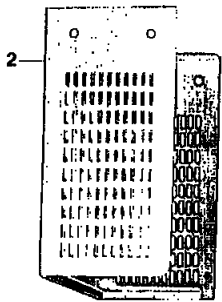
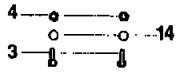
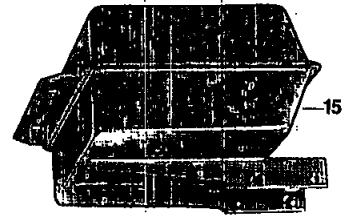
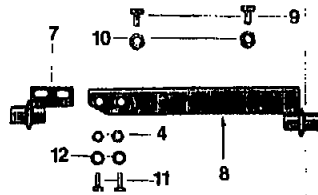
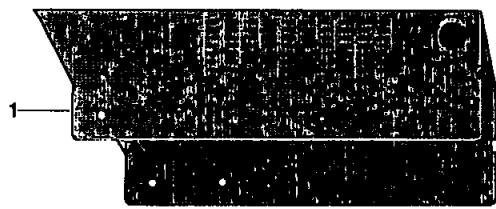

Motorzubehör

Bild-Nr	Anz.	Teilbezeichnung	Sachnummer	Bostell- u Lager-Nr
1		Haube	96-01103-6	35-014
2	1	Schutzgitter	96-01104-4	35-015
	2	Schraube M 6 x 10 DIN 933	11038-05-6	02-526
	4	Mutter M 6 DIN 985	12040-04-4	05-152
3	4	Schraube M 5 x 12 DIN 912	11126-53-9	53-440
4	4	Mutter M 5 DIN 985	12040-03-6	05-134
5	1	Rastbolzen	90-06530-1	53-441
6	1	Mutter BM 8 DIN 439	12012-01-9	04-650
7	1	Halter	96-01105-1	49-004
8	1	Halter	96-01106-9	49-003
9	2	Schraube M 8 x 20 DIN 933	11038-21-3	05-309
	2	Scheibe 8,4 DIN 125	12310-04-1	05-375
10	2	Mutter M 8 DIN 985	12040-05-1	05-151
11	2	Schraube M 6 x 18 DIN 933	11038-08-0	15-421
12	2 4	Scheibe 6,4 DIN 125	12310-03-3	05-373
13	2	Muffe	90-05805-8	05-475
14	4	Scheibe 5,3 DIN 125	12310-02-5	05-372
15	1	Kraftstoffbehälter	96-01088-9	35-016
16	1	Bajonettverschluß B 30	90-05630-0	04-432
17	1	Dichtring	90-00324-5	02-249
18	1	Doppelfiltereinweghahn AA 8/115-850	90-00322-9	06-007
19	1	Benzinschlauch A 5 x 9 x 125 lg.	27670-01-7	25-049
20	4	Schraube M 6 x 20 DIN 912	11126-03-4	02-219
21	4	Federring B 6 DIN 127	12505-04-6	05-340
22	1	Luftleitblech	96-01100-2	20-047
	1	Kabelmuffe 470 0034	15595-02-8	02-719
23	4	Schraube M 8 x 20 DIN 933	11038-21-3	05-309
24	8	Federring B 8 DIN 127	12505-05-3	05-341
25	1	Winkel	90-05809-0	53-442
26	1	Winkel	90-05810-8	53-443
27	1	Klammer	90-05811-6	53-431
28	1	Schraube M 6 x 12 DIN 933	11038-06-4	10-450
29	2	Tellerfeder B 12,5 DIN 2093	16919-06-0	15-653
30	1	Mutter M 6 DIN 985	12040-04-4	05-152
31	2	Schraube M 5 x 18 DIN 933	11038-72-6	10-616
32	2	Scheibe 5,3 DIN 125	12310-02-5	05-372
33	2	Federring B 5 DIN 127	12505-02-8	05-417
34	2	Mutter M 5 DIN 985 985	12040-03-4	05-332 05-134
35	1	Auspufftopf	90-05815-7	20-048
36	1	Motorkonsole	90-05807-4	49-005
37	4	Schraube M 8 x 80 DIN 931	11032-84-4	53-444
38	4	Scheibe 8,4 DIN 125	12310-04-1	05-375
39	1	Öltopf OZV 17/10/1	00125190	12-519
40	1	Gummiring 98 x 108 x 3	00025500	02-550
41	1	Ölbad-Luftfilter OZV 17-2	90-05279-6	01-051
42	1	Spannschelle Sp 41/20 SK	17528-19-1	49-007
43	1	Ansaugstutzen f. Halter Umbausatz	90-05704-1	49-006
44	1	O-Ring 35 x 2,5	15286-50-3	53-446
45	1	Schraube M 6 x 45 DIN 931	11032-09-1	10-686
46	1	Mutter M 6 DIN 985	12040-04-4	05-152
47	1	Schraube M 6 x 22 DIN 933	11038-10-6	15-407
48	2	Federring B 6 DIN 127	12505-04-6	05-340
49	1	Scheibe 6,4 DIN 125	12310-03-3	05-373
50	1	Mutter M 6 DIN 934	12022-04-2	05-333
51	1	Lasche	90-05723-3	53-445
52	1	Schelle	90-06322-3	53-447
53	1	Schraube M 6 x 15 DIN 912	11126-16-6	13-691
54	1	Werkzeugausrüstung	97-00055-8	46-020
43	1	Krümmner		48-026
42	2	Schlauchschelle 545/10 Zy		07-714
43	1	Spannschelle sp. 105/20 SKZ		48-006
43	1	Schlauchschelle - 11 548/19 Zy		66-028
43	1	C-KT-Schr. M6 x 25		05-303
43	1	Sondermutter		07-619
43	1	Halter		48-025

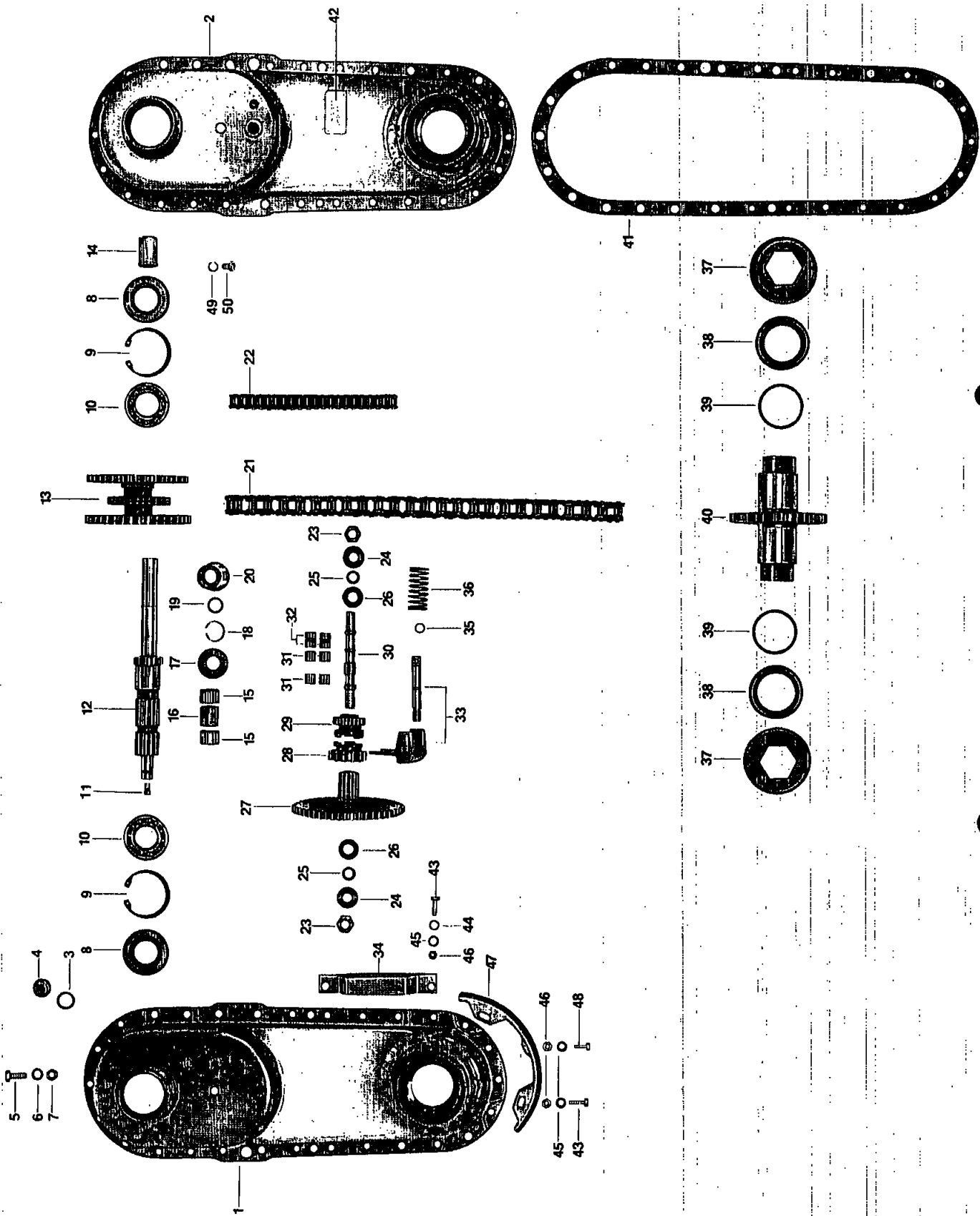

Getriebe

Bild-Nr	Anz.	Teilbezeichnung	Sachnummer	Bestell- u Lager-Nr.
1	1	Gehäusehälfte links	96-01109-3	33-018
2	1	Gehäusehälfte rechts	96-01110-1	33-019
3	1	Fülldichtring C 16 x 22 DIN 7603	15125-03-2	15-314
4	1	Verschlußschraube M16 x 1,5 DIN 910	11530-01-1	15-313
5	5	Schraube M 8 x 20 DIN 933	11038-21-3	05-309
6	5	Federring B 8 DIN 127	12505-05-3	05-341
7	5	Mutter M 8 DIN 934	12022-05-9	05-335
8	2	Dichtung A 30 x 55 x 12 DIN 6503	15244-01-5	05-271
9	2	Sicherungsring 55 x 2 DIN 472	12660-08-0	15-311
10	2	Kugellager 6006 DIN 625	14110-05-0	05-216
11	1	Schmiernippel AM 6 DIN 71412	15715-02-2	04-591
12	1	Ritzelwelle	90-05205-1	17-040
13	1	Blockzahnrad	96-00397-5	17-008
14	1	Gummikappe	90-00968-9	15-388
15	2	Nadelkäfing K 20/17	14673-06-5	05-430
16	1	Abstandsrohr	90-00958-0	15-387
17	1	Anlaufscheibe	90-04441-3	15-122
18	1	V-Ring A 20 x 1,2 V	12626-01-6	15-386
19	1	O-Ring 15 x 2,5	15286-14-9	05-772
20	1	Bundbuchse	90-04442-1	15-385
21	1	Kette 1 x 19,05 x 11,68 x 50 DIN 8187	16365-03-3	17-067
22	1	Hulsenkette A 9,5 x 9,5 x 44 DIN 73232	16368-01-1	25-019
23	2	Mutter M 12 DIN 985	12040-07-7	05-149
24	2	Dichtungsscheibe	90-00963-0	15-111
25	2	O-Ring 11,8 x 16	15286-12-3	15-307
26	2	Anlagescheibe	90-00404-5	13-525
27	1	Zahnrad	90-01810-2	17-051
28	1	Schieberritzel	90-00615-6	29-017
29	1	Kettenritzel	90-01809-4	29-018
30	1	Lagerbolzen	90-00960-6	15-389
31	2	Nadelkäfig K 12/13	14673-08-1	15-390
32	2	Nadelhülse K 12 x 15 x 9	14673-07-3	15-109
33	1	Schaltgabel vollst.	96-00123-5	25-024
34	1	Steinschlagschutz	90-01333-5	17-017
35	1	O-Ring 8 x 2	15286-47-9	15-115
36	1	Druckfeder	90-00971-3	15-114
37	2	Schutzkappe	90-00430-0	17-049
38	2	Wellendichtring	90-04585-7	08-060
39	2	Nadelhülse HK 4520	14674-02-2	08-046
40	1	Werkzeugwelle vollst.	96-00387-6	17-071
41	1	Dichtung	90-00965-5	17-013
42	2	Olstandschild	90-00926-7	02-493
43	6	Schraube M 6 x 20 DIN 933	11038-09-8	05-302
44	4	Scheibe 6,4 DIN 125	12310-03-3	05-373
45	6	Federring B 6 DIN 127	12505-04-6	05-340
46	13	Mutter M 6 DIN 934	12022-04-2	05-333
47	1	Schleifschutz	90-00966-3	17-059
48	13	Schraube M 6 x 15 DIN 933	11038-07-2	05-301
49	1	Fülldichtung C 8 x 12 DIN 7603	15125-02-4	15-409
50	1	Schraube AM 8 x 10 DIN 84	11105-09-5	15-315

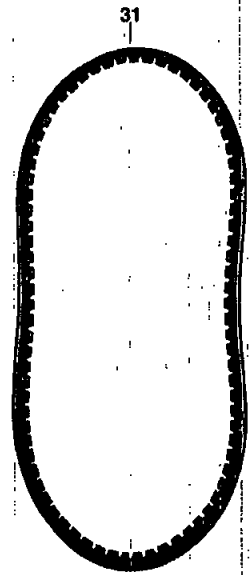
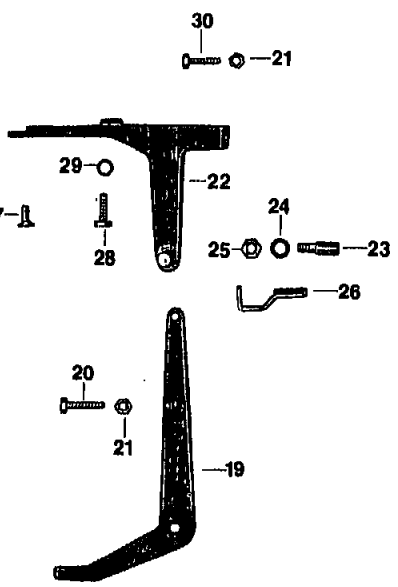
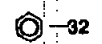
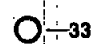
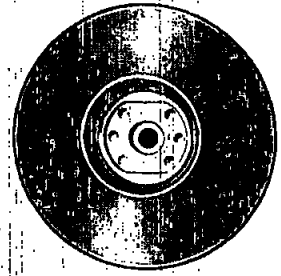
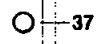
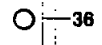
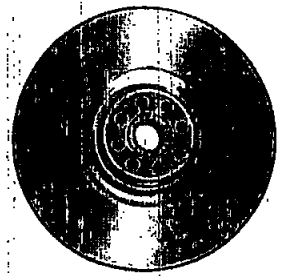
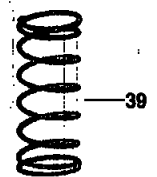
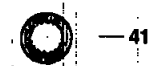
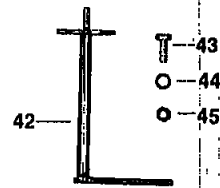
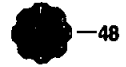
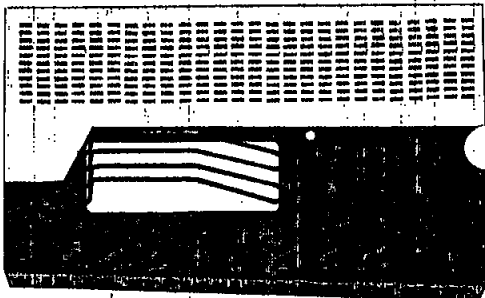
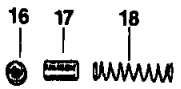
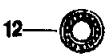
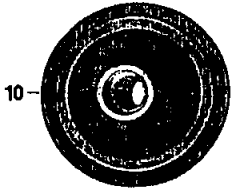
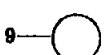
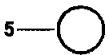
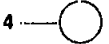
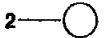
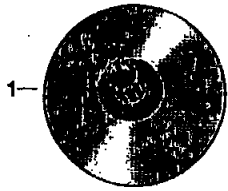

HAKOmatic-Verstelltrieb

Bild-Nr.	Anz.	Teilbezeichnung	Sachnummer	Bestell- u. Lager-Nr
1	1	Scheibenhälfte fest	96-00263-9	36-028
2	1	O-Ring 30 x 2	15286-09-9	15-265
3	1	Dichtring G 40 x 50 x 4	15264-04-7	15-262
4	1	Sprengtring WR 40	12565-01-6	15-263
5	1	Anlaufscheibe	90-01647-8	15-261
6	1	Nadelhülse HK 4020	14674-05-5	08-035
7	1	Keilriemenhülse	90-01646-0	42-012
8	1	Dichtring SD 40 x 47 x 4	15264-05-4	15-264
9	1	Anlaufscheibe	90-01653-6	53-456
10	1	Scheibenhälfte lose	96-00260-5	36-032
11	1	Federteller	90-01655-1	07-405
12	1	Kugellager 6203 Z DIN 625	14110-15-9	05-221
13	1	Druckzapfen	90-05654-0	15-266
14	1	Kegel-Schmiernippel AM 6	15715-02-2	04-591
15	1	Sicherungsring 40 x 1,75 DIN 472	12660-04-9	13-310
16	1	Schlitzmutter	90-01386-3	13-304
17	1	Distanzbuchse	90-00222-1	05-141
18	1	Druckfeder	90-01645-2	13-308
19	1	Schalthebel	96-01083-0	20-054
20	1	Schraube M 8 x 35 DIN 933	11038-26-2	05-469
21	2	Mutter M 8 DIN 934	12022-05-9	05-335
22	1	Hebellager	90-05721-7	20-055
23	1	Hebelbolzen	90-01656-9	02-230
24	1	Federring B 10 DIN 127	12505-06-1	05-342
25	1	Mutter BM 10 DIN 439	12012-02-7	07-471
26	1	Winkel vollst	96-01082-2	53-455
27	1	Senkschraube M 8 x 25 DIN 7991	11225-02-6	13-635
28	2	Schraube M 8 x 25 DIN 933	11038-24-7	05-310
29	2	Federring B 6 DIN 127	12505-05-3	05-341
30	1	Schraube M 8 x 30 DIN 933	11038-25-4	05-311
31	1	Breitkeilriemen 30 x 13 x 1080	90-05722-5	36-039
32	1	Mutter M 16 DIN 936	12015-03-8	07-428
33	1	Schnorr-Sicherung M 16	90-01673-4	15-270
34	1	Scheibenhälfte außen	96-00261-3	36-036
35	1	Spannelement 16 x 20	13570-01-5	15-269
36	1	Distanzstück	90-01650-2	15-268
37	1	Scheibenhälfte innen	96-00262-1	36-035
38	1	Federhülse innen	90-01651-0	42-019
39	1	Druckfeder	90-01649-4	42-018
40	1	Federhülse außen	90-01648-6	42-013
41	1	Verstärkungshülse	90-01652-8	15-267
42	1	Haubenhalter	96-01092-1	49-014
43	1	Schraube M 8 x 25 DIN 933	11038-24-7	05-310
44	1	Federring B 8 DIN 127	12505-05-3	05-341
45	1	Mutter M 8 DIN 934	12022-05-9	05-335
46	1	Scheibe	90-00362-5	05-168
47	2	Gummischeibe	90-00361-7	05-167
48	1	Handrad 56 / M 8	17133-01-8	48-043
49	1	Riemenverkleidung	96-01084-8	35-021

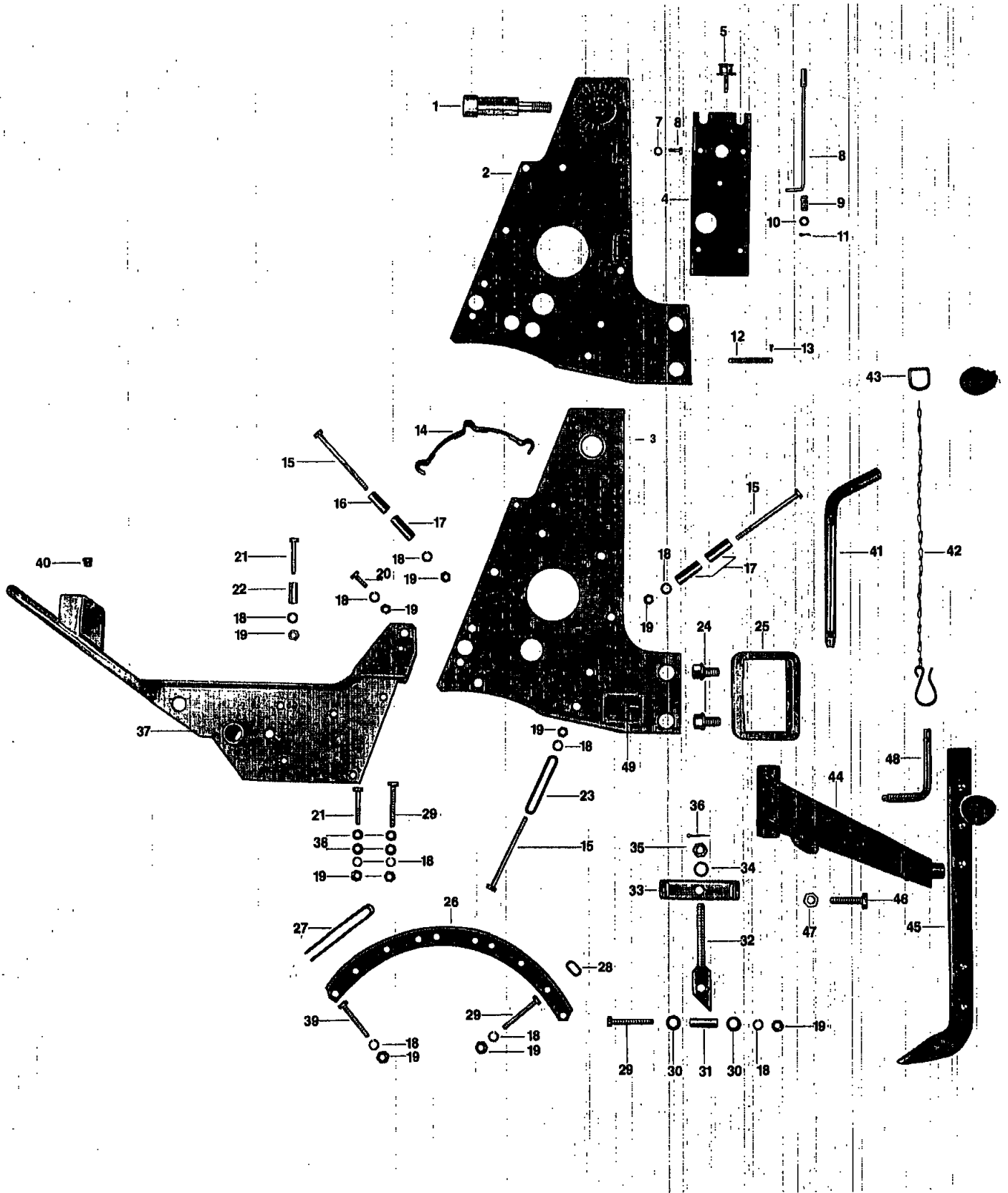

**Motorkonsole, Seitenwand, Tragebogen, Bremssporn,
Vorstecker, Schilder, Aufkleber**

Bild-Nr	Anz.	Teilbezeichnung	Sachnummer	Bestell- u Lager-Nr
1	1	Druckschraube	90-05779-5	53-426
2	1	Seitenwand rechts	96-01091-3	20-046
3	1	Seitenwand links	96-01090-5	20-045
4	1	Blech	90-05775-3	53-424
5	1	Steckdose 0353 222 003	90-05763-9	53-427
6	2	Schraube M 6 x 15 DIN 933	11038-07-2	05-301
7	2	Federring B 6 DIN 127	12505-04-6	05-340
8	1	Hebel	96-01107-1	53-425
9	1	Druckfeder	90-01568-6	04-623
10	1	Scheibe 6,4 DIN 125	12310-03-3	05-373
11	1	Splint 2 x 15 DIN 94	13280-07-8	05-486
12	1	Nummernschild	90-00014-2	15-388
13	10	Halbrundkerbnagel 3 x 4 DIN 1476	13250-03-0	53-433
14	1	Abstandsbügel	90-05757-1	27-061
	1	Abstandsbügel m. Rohr f. Bowdenzug	96-01094-7	27-063
15	7	Schraube M 8 x 100 DIN 931	11032-27-3	05-314
16	1	Abstandsrohr	90-05761-3	53-420
17	3	Klemmrohr	90-01317-8	15-339
18	21	Federring B 8 DIN 127	12505-05-3	05-341
19	21	Mutter M 8 DIN 934	12022-05-9	05-335
20	8	Schraube M 8 x 20 DIN 933	11038-21-3	05-309
21	2	Schraube M 8 x 45 DIN 931	11032-20-8	05-312
22	1	Abstandsrohr	90-05764-7	53-422
23	2	Klemmbügel hinten	90-01311-1	15-337
24	4	Radschraube	90-01308-7	13-718
25	1	Geräteanhangung	90-01309-5	25-043
26	2	Tragebogen	90-00429-2	44-033
27	1	Abstandsbügel	90-05762-1	53-421
28	2	Klemmbügel	90-01320-2	15-344
29	3	Schraube M 8 x 55 DIN 933	11038-30-4	05-313
30	2	Abstandsrohr	90-01306-1	15-347
31	1	Abstandsrohr	90-01307-9	15-346
32	1	Spannerbolzen	90-00427-6	12-215
33	1	Spannbrücke	90-00428-4	12-212
34	1	Federring B 12 DIN 127	12505-07-9	05-343
35	1	Mutter M 12 DIN 934	12022-07-5	05-337
36	1	Splint 3 x 25 DIN 94	13280-14-4	05-487
37	1	Motorkonsole	96-01089-7	20-044
	1	Klammer z. Befestigung d Haube	90-05811-6	53-431
	1	Winkel z. Befestigung d. Haube	90-06337-1	53-432
	2	Schraube M 5 x 18 DIN 933	11038-72-6	10-616
	2	Schraube AM 5 x 15 DIN 63	11205-04-4	13-220

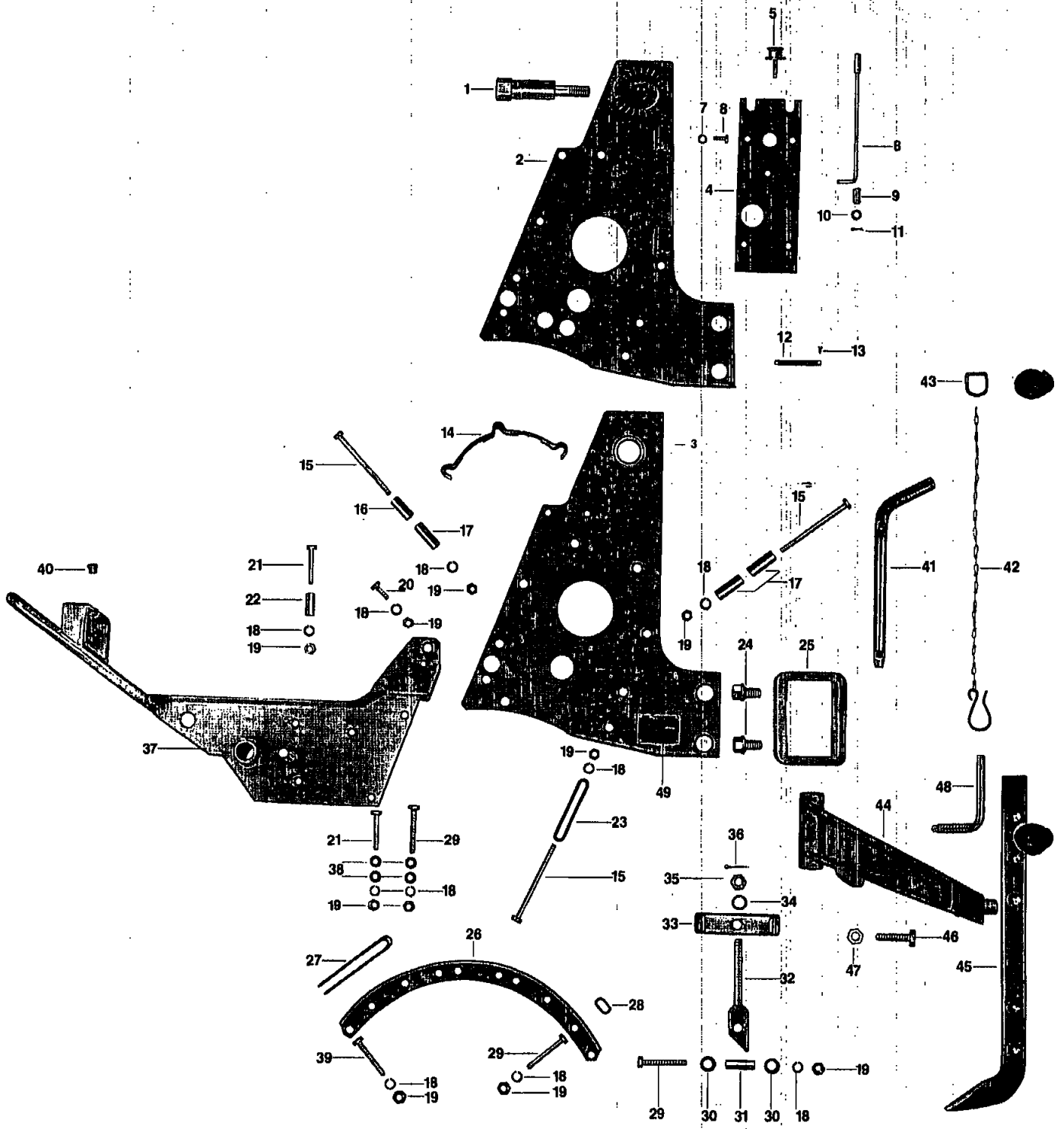

**Motorkonsole, Seitenwand, Tragebogen, Bremssporn,
Vorstecker, Schilder, Aufkleber**

Bild-Nr	Anz.	Teilbezeichnung	Sachnummer	Bestell- u Lager-Nr
	2	Scheibe 5,3 DIN 125	12310-02-5	05-372
	4	Mutter M 5 DIN 985	12040-03-6	05-134
38	4	Buchse	90-05773-8	53-423
39	2	Schraube M 8 x 50 DIN 933	11038-29-6	05-326
40	2	Kabelmuffe 470 00 37	15594-02-1	53-428
41	1	Vorstecker 16 1/2	90-01218-8	17-035
42	1	Ketter 2 x 16 Gl. DIN 5686 m. Haken	16325-02-9	05-119
43	1	Zugring	90-00416-9	02-522
44	1	Bremsspornhalter	90-01092-7	44-038
45	1	Bremssporn	90-01223-8	30-035
46	2	Schraube M 12 x 40 DIN 933	11038-49-4	05-322
47	2	Mutter M 12 DIN 934	12022-07-5	05-337
48	2	Gewindehebel	90-01091-9	30-036
49	1	Typenschild (Kupplungseinrichtung)	90-02146-0	53-434
4	1	Typenschild (HAKOrette RG)	90-06400-7	53-435
1	1	Aufkleber „Ölstand beachten“	90-05995-7	53-437
	1	Aufkleber zum Benzinhahn	90-05996-5	53-438
	1	Aufkleber zum Leerlauf	90-05997-3	53-439
	1	Aufkleber „HAKO“	90-05998-1	49-001
	4	Schriftzug „HAKOrette“	90-05999-0	49-002
	2	Firmenzeichen	17200-03-1	53-605
	2	Namenszug HAKOrette	17205-02-2	53-612
	1	Typenschild	17248-01-7	53-435
	1	Typenschild Kupplungseinr.	17223-01-7	53-434
	1	Aufkleber	17257-05-6	53-634
	3	Aufkleber	17256-01-7	53-437
	1	Aufkleber	17205-01-6	53-606
Zu 37	* 1	Vorstecker		62-019
	* 1	Spannhülse 5x28 DIN 1481		05-113
	* 1	Vorstecker		05-286
	* fünf	Frontgewicht 3128		

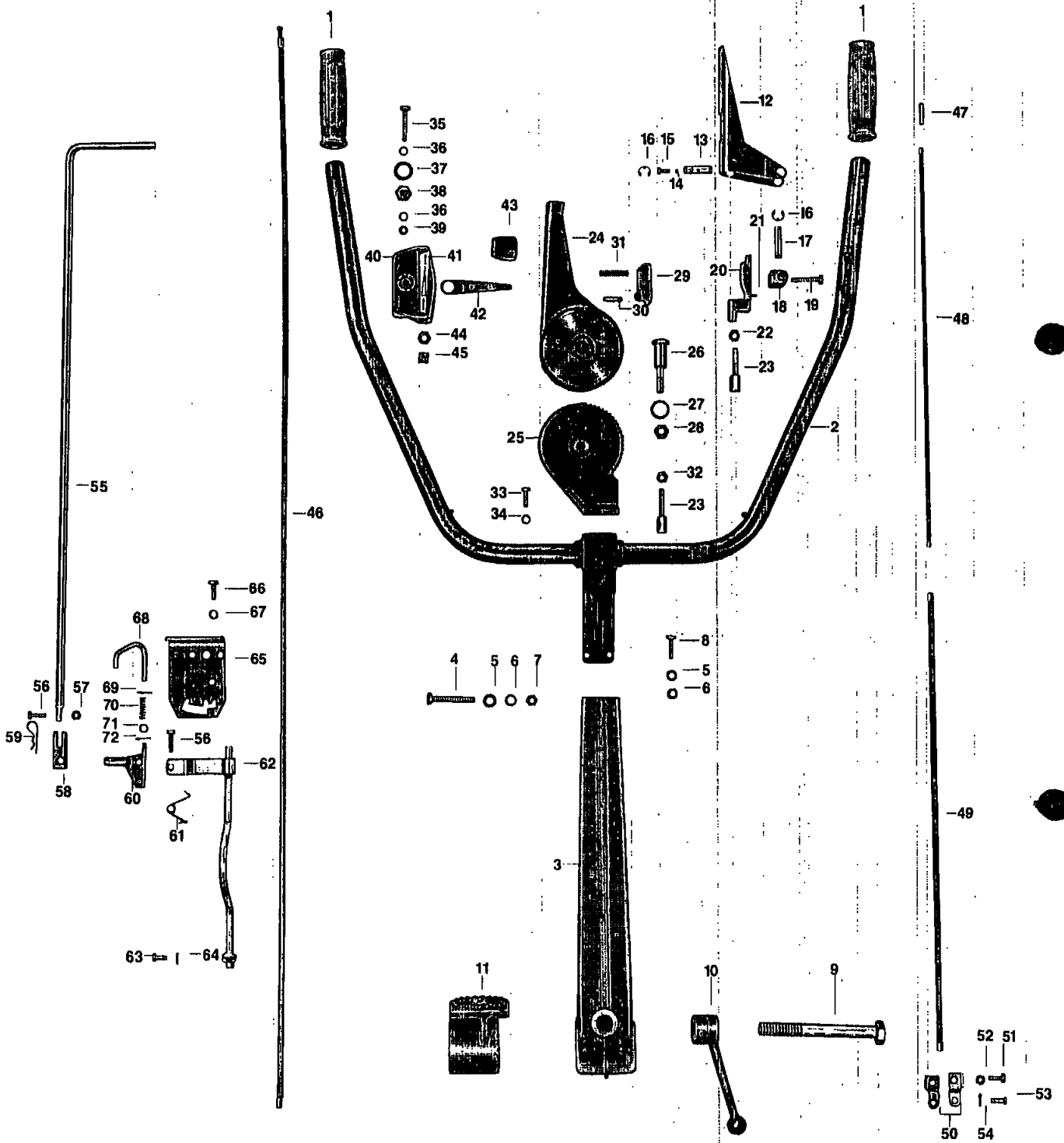

**Holm, Schalthebel, HAKOmatic-Verstellhebel,
Spannrollenhebel, Schaltung**

Bild-Nr	Anz.	Teilbezeichnung	Sachnummer	Bestell- u. Lager-Nr
1	2	Plastikgriff grau 25 x 100	90-00338-5	14-012
2	1	Griffrohr	96-01096-2	35-018
	2	O-Ring 30 x 3	15286-46-1	05-475
	2	Muffe	90-05805-8	02-475
3	1	Holmrohr	96-01097-0	20-050
4	1	Schraube M 8 x 60 DIN 931	11032-23-2	07-426
5	4	Scheibe 8,4 DIN 125	12310-04-1	05-375
6	3	Federring B 8 DIN 127	12505-05-3	05-341
7	1	Mutter M 8 DIN 934	12022-05-9	05-335
8	2	Schraube M 8 x 22 DIN 933	11038-23-9	07-711
9	1	Schraube M 16 x 150 DIN 931	11032-83-6	49-011
10	1	Hebel	90-05793-6	49-010
11	1	Holmsockel	90-05778-7	27-062
12	1	Handhebel	90-03256-6	21-002
13	1	Bolzen	90-04320-9	07-606
14	1	Kugel 3,5 V DIN 5401	14620-03-3	07-605
15	1	Schraube M 5 x 12 DIN 933	11038-03-1	15-280
16	4	Sicherungsscheibe 8 DIN 6789	12640-03-3	04-628
17	1	Bolzen	90-03263-2	07-604
18	1	Gelenkstück	90-03258-2	07-608
19	1	Schraube AM 6 x 35 DIN 84	11105-10-3	07-609
20	1	Kulisse	90-05118-6	39-052
21	1	Spiralstift S 3 x 16	13053-01-2	13-690
22	1	Mutter BM 8 DIN 439	12012-01-9	04-650
23	2	Stellschraube M 8	90-00333-6	07-429
24	1	Griff	90-01686-6	42-003
25	1	Grundplatte	90-05794-4	49-015
26	1	Schwenkwelle	90-05795-1	53-457
27	1	Paßscheibe PS 17 x 24 x 0,5	12336-14-5	12-568
28	1	Mutter M 10 DIN 985	12040-06-9	05-150
29	1	Sperrklinke	90-01687-4	15-251
30	1	Spannhülse 6 x 24 DIN 1481	13050-06-7	15-252
31	1	Druckfeder	90-01684-1	15-250
32	1	Mutter M 8 DIN 934	12022-05-9	05-335
33	2	Schraube M 6 x 20 DIN 933	11038-09-8	05-302
34	2	Federring B 6 DIN 127	12505-04-6	05-340
35	1	Schraube M 6 x 45 DIN 933	11038-81-7	02-155
36	2	Scheibe 6,4 DIN 125	12310-03-3	05-373
37	1	Paßscheibe 15 x 22 x 0,3 Federscheibe B 12 DIN 107	12510-04-6	05-387 53-492
38	1	Federscheibe B 12 Distanzstück	90-04730-9	05-387 07-616
39	1	Mutter M 6 DIN 985	12040-04-4	05-152
40	1	Schaltblech	90-04303-5	21-004
41	1	Aufkleber	90-03936-3	07-617

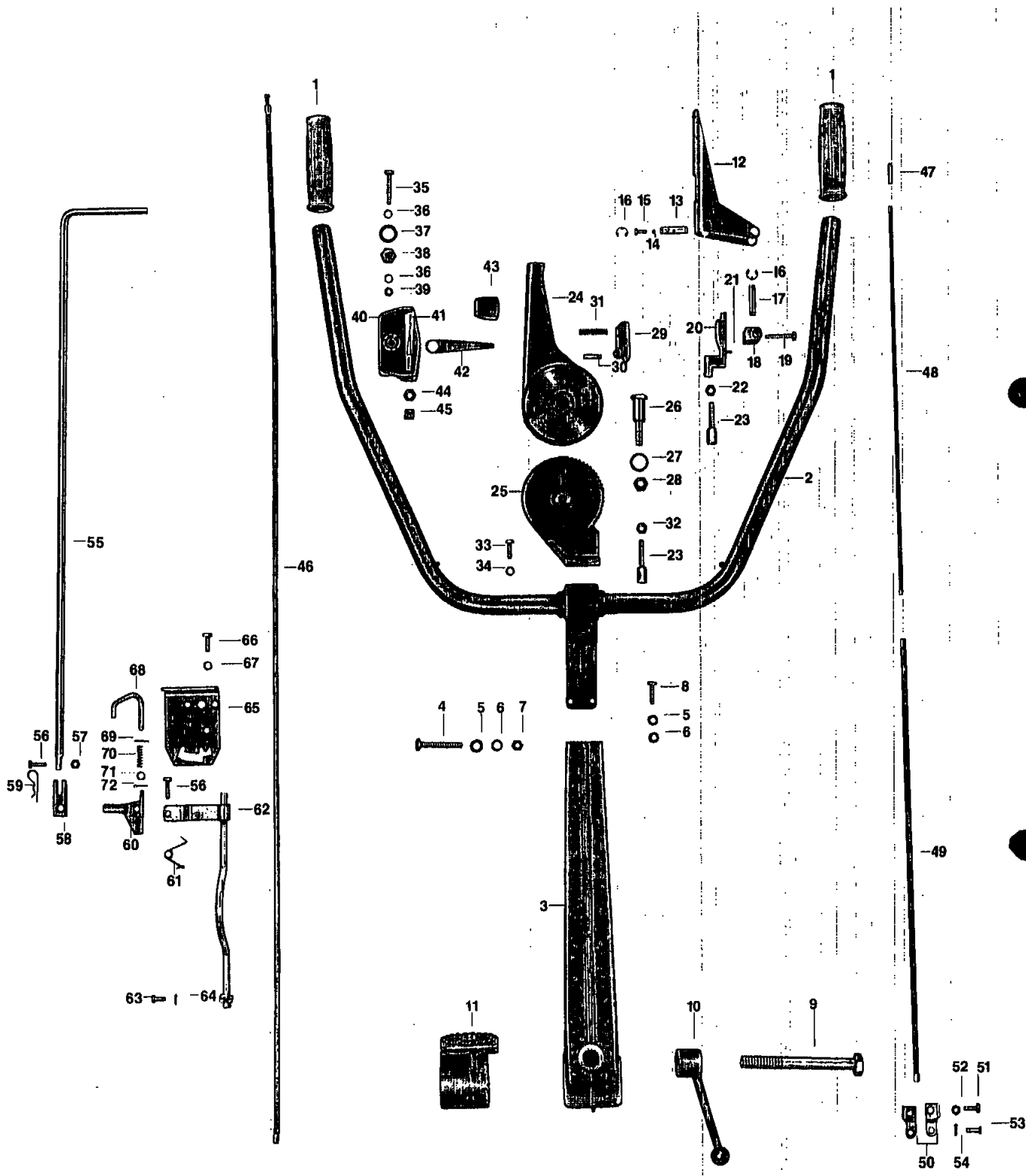

**Holm, Schalthebel, HAKOmatic-Verstellhebel,
Spannrollenhebel, Schaltung**

Bild-Nr	Anz.	Teilbezeichnung	Sachnummer	Bestell- u Lager-Nr
42	1	Schalthebel	90-04302-7	07-614
43	1	Hebelknopf	90-04301-9	07-613
44	1	Sondermutter	90-04316-7	07-619 λ
45	1	Schraubnippel	90-04300-1	07-618 λ
46	1	Bowdenzug	90-05817-3	24-045 24-058
	1	Kabelmuffe 470 0034	15595-02-8	02-719
47	1	Abstandsrohr	90-05820-7	53-452
48	1	Bowdenzug	96-00269-6	24-006
49	1	Bowdenzug	96-01102-8	24-046
50	1	Klemmschelle	90-01679-1	15-255
51	1	Schraube M 6 x 15 DIN 933	11038-07-2	05-301
52	1	Mutter M 6 DIN 985	12040-04-4	05-152
53	1	Bolzen 6 h 11 x 16 x 12 DIN 1434 ^{6 h 11 x 14,5 DIN 1434}	13328-01-8 ⁰²⁻⁶	13-320 15-742
54	1	Splint 1,5 x 10 DIN 94	13280-27-6	53-454
55	1	Zugstange	90-05725-8	20-051
56	21	Schraube M 6 x 25 DIN 933	11038-11-4	05-303
57	2	Mutter M 6 DIN 985 ^{M 6 x 3 DIN 933}	12040-04-4	05-329
58	1	Gelenk ^{B 16 DIN 439}	90-05729-0	05-152
59	1	Vorstecker	90-05726-6	53-452
59	1	Vorstecker	90-05726-6	53-449
60	1	Lasche	96-01085-5	53-448
61	1	Drehfeder	90-05727-4	53-450
62	1	Schaltstange	96-01086-3	49-013
	1	Paßscheibe 10 x 16 x 1 DIN 988	12335-12-1	15-543
63	1	Bolzen 5 h 11 x 16 x 14 DIN 1435	13330-01-4	15-381
64	1	Splint 1,5 x 10 DIN 94	13280-27-6	53-454
65	1	Kulisse	90-05730-8	49-012
66	2	Schraube M 6 x 25 DIN 912	11126-04-2	02-222
67	2	Federring B 6 DIN 127	12505-04-6	05-340
68	1	Sperre	90-05728-2	53-451
69	1	Spiralstift S 2 x 20	13053-11-1	05-777
70	1	Druckfeder	90-05736-5	53-453
71	3	Scheibe 6,4 DIN 125	12310-03-3	05-373
72	1	Splint 2 x 15 DIN 94 ^{1,5 x 20 DIN 94}	13280-07-8	05-480 05-182
Zus 3	1	Scheibe 6,4 DIN 125	12310-03-3	05-373
	1	Mutterung f. Bowdenzug		50-206 λ