

Ersatzteilliste

Spare parts list

Liste de pièces de rechange

Lista de piezas de recambio

Listino per pezzi di ricambio

HAKO

Hako-Combinette (3604)

... ..

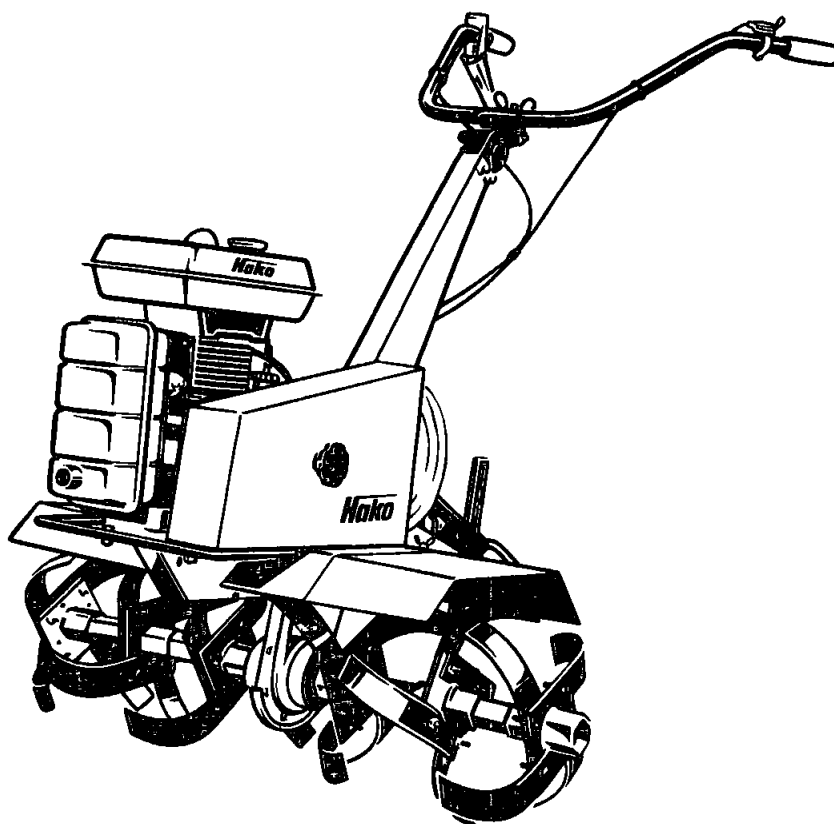

**Bestellen Sie Ersatzteile grundsätzlich bei Ihrem Werkstützpunkt
und machen Sie folgende Angaben:**

1. Gerätetype, Motor- und Gerätenummer
2. Genaue Bezeichnung des gewünschten Teiles sowie **Bestell- und Lagernummer**. Keine Bildnummer angeben.
3. Art des Versandes: z. B. Post, Fracht oder Express.
4. Genaue Anschrift mit Postleitzahl; bei Bahnversand Stationsbezeichnung.
5. In Zweifelsfällen Muster einsenden, Lieferschein oder Begleitschreiben beigeben.
6. Rückgabe der Musterteile erfolgt nur, wenn ausdrücklich verlangt.

Verwenden Sie nur Original-Ersatzteile!

I n h a l t

S e i t e

Kurbelwelle, Zylinder, Kolben, Lüfter, Reversierstarter	1 - 4
Vergaser, Zündanlage	5 - 8
Motorzubehör, Spannrolle, Keilriemenscheibe	9 - 12
Getriebe, Schutzblech, Träger	13 - 16
Holm, Spannrollenhebel, Bremssporn	17 - 18

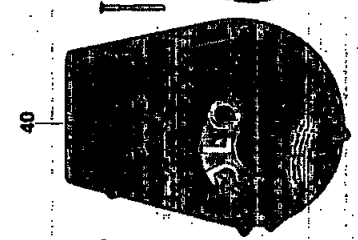
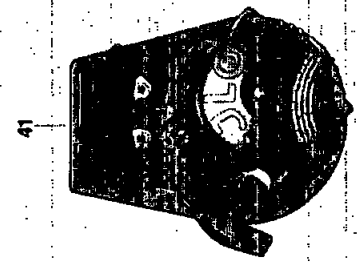
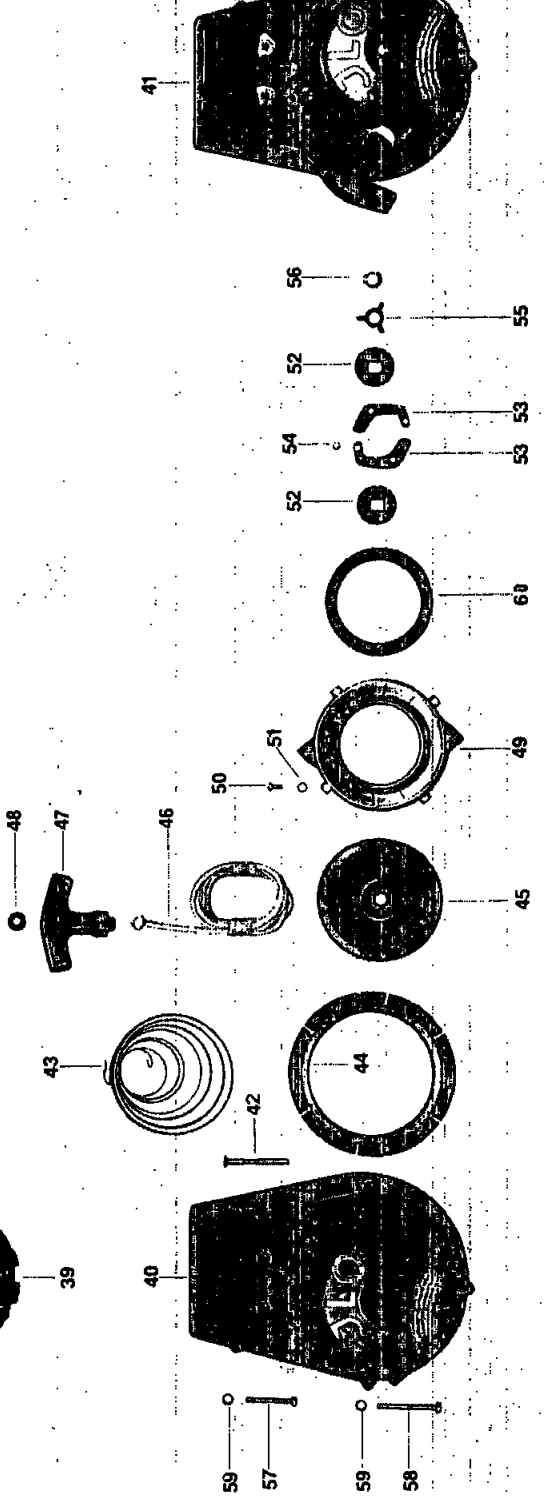
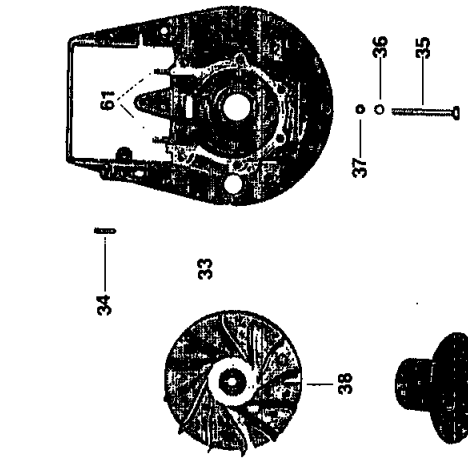
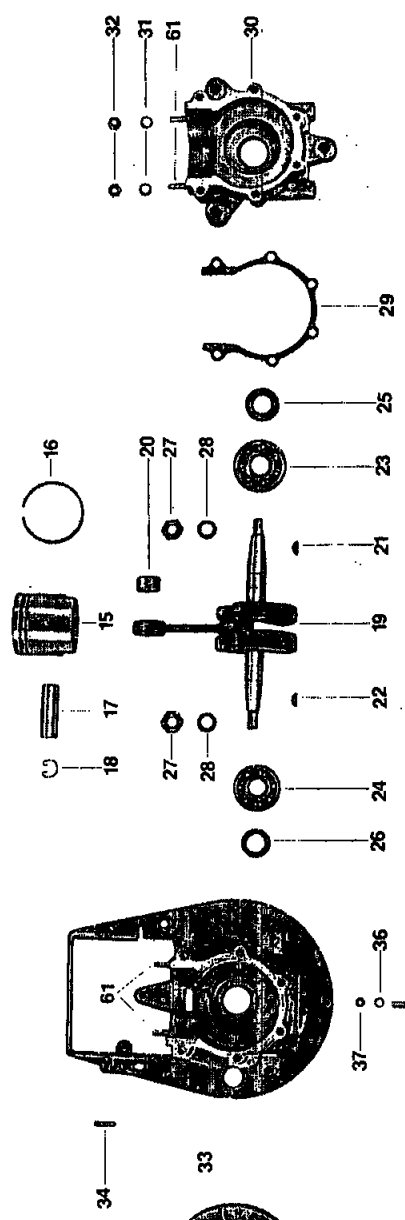
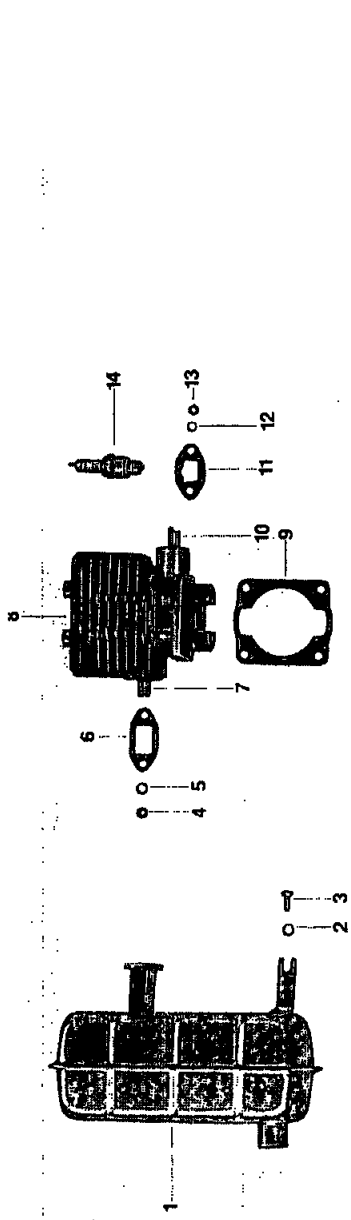

Kurbelwelle, Zylinder, Kolben, Auspuff, Lüfter, Reversierstarter
für ILO - Motor L 99 (90-07152-3)

Bild-Nr.	Anz.	Teilbezeichnung	Sachnummer	Bestell- u. Lager-Nr.
1	1	Auspufftopf	099.29-801-00	43-052
2	1	Scheibe 5,3 DIN 125	12310-02-5	05-372
3	1	Schraube AM 5x15 DIN 7513	000.41-61.122	53-301
4	2	Mutter M 6 DIN 934	12022-04-2	05-333
5	2	Federring B 6 DIN 127	12505-04-6	05-340
6	1	Auspuffdichtung	077.07-729-00	53-302
7	2	Stiftschraube (nur mit Teil 8 gemeinsam lieferbar		
8	1	Zylinder	099.07-006-12	43-082
9	1	Zylinderfußdichtung	079.07-002-00	53-303
10	2	Schraube M 6 x 20 DIN 933	11038-09-8	05-302
11	1	Vergaserdichtung	320.07.027-10	02-422
12	2	Federring B 6 DIN 127	12505-04-6	05-340
14	1	Zündkerze Bosch W 190 M 11 S	---	43-054
15	1	Kolben	099.05-900-00	43-055
16	2	Kolbenring 55,0 Ø x 2	000.42.12-358	53-306
17	1	Kolbenbolzen	099.05-002-00	53-307
18	2	Sprengtring A 15 DIN 73123	000.40-62.121	53-308
19	1	Kurbelwelle	079.86-901-00	43-056
20	1	Nadelhülse	000.39-10.810	43-057
21	1	Scheibenfeder 3x5 DIN 6888	000.40-89.020	53-309
22	1	Scheibenfeder 2x3,7 DIN 6888	000.40-89-012	53-310
23	1	Kugellager 6303 DIN 625	---	05-237
24	1	Kugellager 6302 DIN 625	14110-34-0	04-707
25	1	Dichtring A 17x28x7/8	00042-31.228	53-311
26	1	Dichtring A 15x24x7 DIN 3760	000.42-31.171	53-312
27	2	Mutter M 10 DIN 934	12022-06-7	05-336
28	2	Federring B 10 DIN 127	12505-06-1	05-342
29	1	Dichtung	079.01-005-10	53-313
30	1	Gehäusedeckel	079.01-003-00	43-058
31	4	Federring B 6 DIN 127	12505-04-6	05-340
32	4	Mutter M 6 DIN 934	12022-04-2	05-333
33	1	Gehäuse	079.01-027-10	43-083
34	1	Spannhülse 4 x 20 DIN 1481	13053-02-0	10-260
35	6	Schraube M 5 x 55 DIN 931	---	05-327
36	6	Federring B 5 DIN 127	12505-03-8	05-417
37	6	Mutter M 5 DIN 934	12022-03-4	05-332
38	1	Lüfterrad	079.14-014-20	43-060
39	1	Mitnehmer*opf	079.41-801-00	43-061
40	1	Lüfterhaube schwarz 9 h	079.14-803-20	43-062
41	1	Reversierstarter vollst.	079.41-809-20	43-063
42	1	Kurzschlußbetätigung	079.11-005-00	53-314
43	1	Rückholfeder	079.41-008-10	43-064
44	1	Abdeckring	079.14-012-10	43-084
45	1	Seilscheibe	079.41-001-11	43-066
46	1	Starterseil 1300 Lg.	002.42-294-00	53-315
47	1	Handgriff	079.41-013-00	43-067
48	1	Scheibe	079.41-017-00	53-316
49	1	Abdeckblech	079.41-011-02	43-068
--	1	Dichtung für Abdeckblech	079.41-014-00	43-069
50	4	Kerbschraube 3,9x9,5 DIN 7981	000.41-61-965	53-317
51	4	Federring B 4 DIN 127	12505-02-0	15-424
52	2	Mitnehmerscheibe	079.41-006-01	53-318



Bild-Nr.	Anz.	Teilbezeichnung	Sachnummer	Bestell- u. Lager-Nr.
n.Red.		Ausgleichscheibe	079.41-019-00	53-319
53	2	Starterklinke	079.41-005-10	53-320
54	2	Reibklotz	079.41-010-00	53-321
55	1	Druckfeder	079.41-007-00	53-322
56	1	Sicherungsring 10 x 1,2	000.40-60-310	53-323
57	2	Schraube AM 5 x 40 DIN 84	000.41-50.124	53-324
58	3	Schraube AM 5 x 50 DIN 84	000.41-50.126	53-386
59	5	Sicherung	000.40-64.310	53-387
60	1	Dichtung	079.41-018-00	43-070
61	4	Stiftschraube M 6x18 DIN 835	000.41-27-049	53-389
		Reparatursätze für L 99		
	1	Zylindersatz für L 99 (Zylinder, Kolben, Dichtungen)	099.92-901-01	43-071
	1	Dichtungssatz mit Dichtringen	079.61-806-00	43-072
	1	Rumpfmotor L 99, Abtrieb konisch (ohne Magnetzündler, Lüfter, Vergaser, Auspuff u. sonst. Zubehör)	099.60-0001-00	35-008
	1	<i>Motor L99 kpl.</i>	<i>90-07152-3</i>	<i>57-024</i>



Vergaser, Zündanlage

Bild-Nr.	Anz.	Teilbezeichnung	Sachnummer	Bestell-u. Lager-Nr.
1	1	Vergaserstutzen	315.07-020-30	53-483
2	1	Kerbstift 2x10 DIN 1473	0021060	02-106
3	1	Klemmschraube	40-614	15-206
4	1	Vergaser	1/19/376	49-036
5	1	Leerlaufdüse	44-911/40	15-228
6	1	Tupfer	48-987	15-211
7	1	Feder	60-055	15-219
8	1	Sicherungsscheibe	61-620	15-218
9	1	Luftregulierschraube	50-012	15-212
10	1	Feder	60-075	15-220
11	1	Stellschraube	50-078	15-214
12	1	Feder	60-282	15-221
13	1	Schlauchtülle	51-320	15-216
14	1	Sieb	57-695	15-227
15	1	Dichtring A 8 x 11,5 DIN 7603	000.35-00.070	15-224
16	1	Nadelhülse	45-295/1108	15-208
17	1	Hauptdüse	44-051/95	15-232
18	1	Stift	50-080	15-217
19	1	Schwimmer	35-225	15-204
20	1	Schwimmernadel	47-062	15-210
21	1	Dichtung	65-580	15-226
22	1	Schwimmergehäuse	30-550	15-203
23	2	Schraube	40-416	15-205
24	2	Federring	61-675	04-130
25	1	Dichtring	65-204	15-225
26	1	Verschlußschraube	50-240	15-215
27	1	Stellschraube	50-050	15-213
28	1	Mutter	42-605	15-207
29	1	Deckelverschraubung	21-220	15-201
30	1	Schieberfeder	60-345	15-222
31	1	Sicherungsscheibe	57-220	15-223
32	1	Düsennadel	46-081	15-209
33	1	Gasschieber	22-260	15-202
<u>Zündanlage</u>				
34	1	Zündkerze Bosch W 190 M 11 S		43-054
35	1	Kerzenstecker BA 4/14 F	90-04022-1	02-705
36	1	Gummitülle	002.44-465-90	53-362
37	1	Kabeldurchführung	002.44-423-90	53-361
38	1	Schutzschlauch 80 Lg.	002.44-131-08	53-360
39	1	Zündspule	000.43-05.577	43-074
40	2	Federring B 6 DIN 127	12505-04-6	05-340
41	2	Schraube M 6x25 DIN 933	11038-11-4	05-303
42	1	Steckhülse	002.44-523-00	53-484
--	2	Steckhülse	002.44-522-00	53-364
43	1	Kurzschlußkabel 90 Lg.	002.44-142-09	53-485
--	1	Kurzschlußkabel 130 Lg.	002.44-142-13	53-367
44	1	Kabelschuh	000.43-10-002	53-385
45	1	Kondensator	000.43-06.512	53-366
46	2	Isoliertülle	002.44-560-00	53-365
47	1	Kurzschließer	079.11-009-01	53-368
48	1	Isolierbuchse	079.11-010-00	53-369
49	1	Verbinder	079.11-801-00	53-370
50	1	Staubschutzkappe	079.11-802-00	53-376

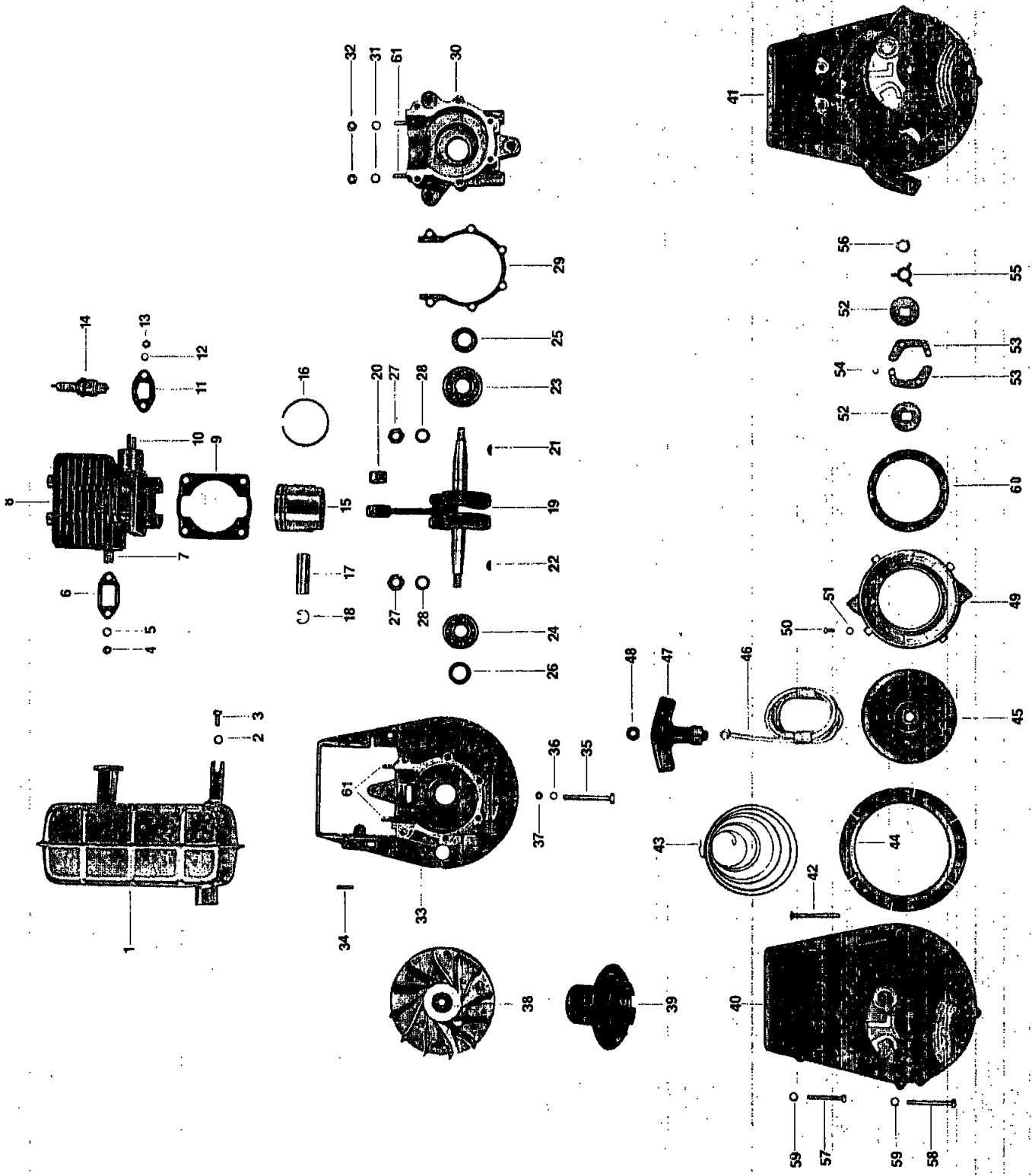
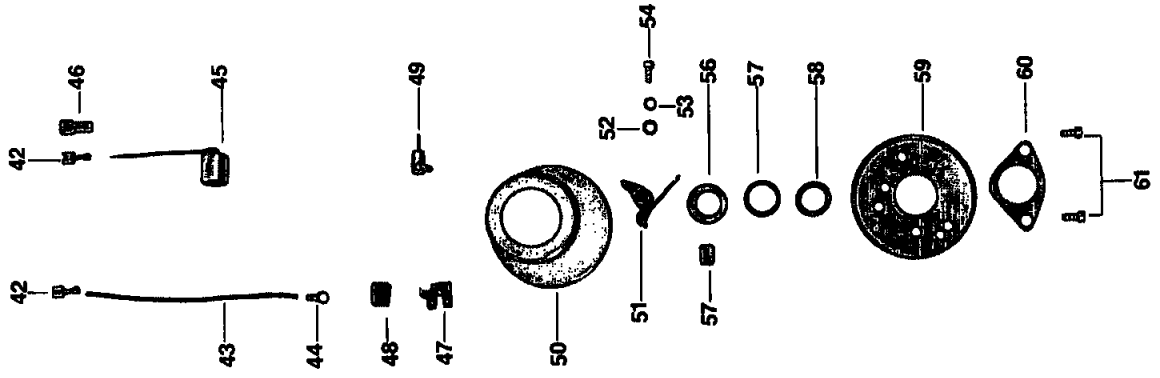
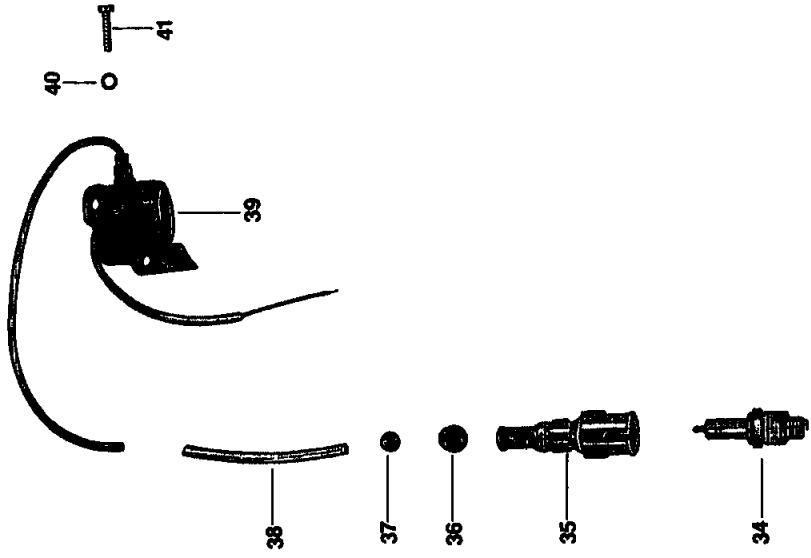
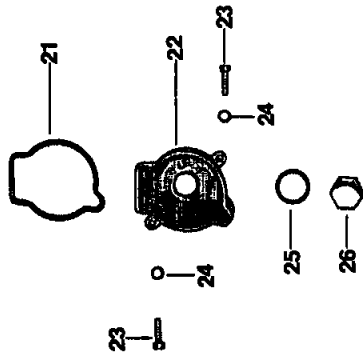
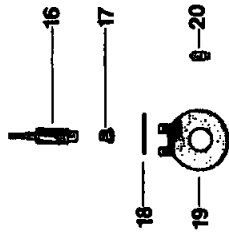
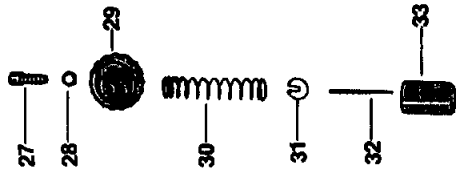
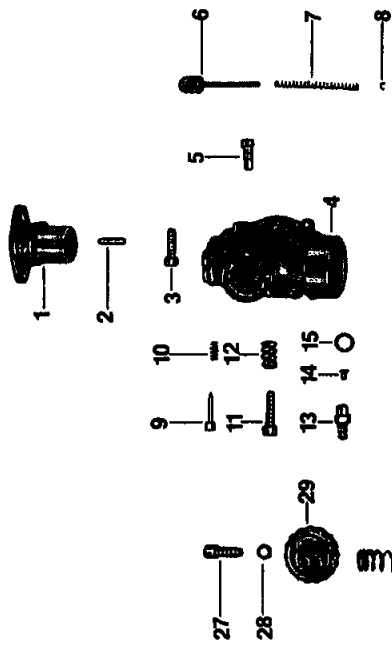
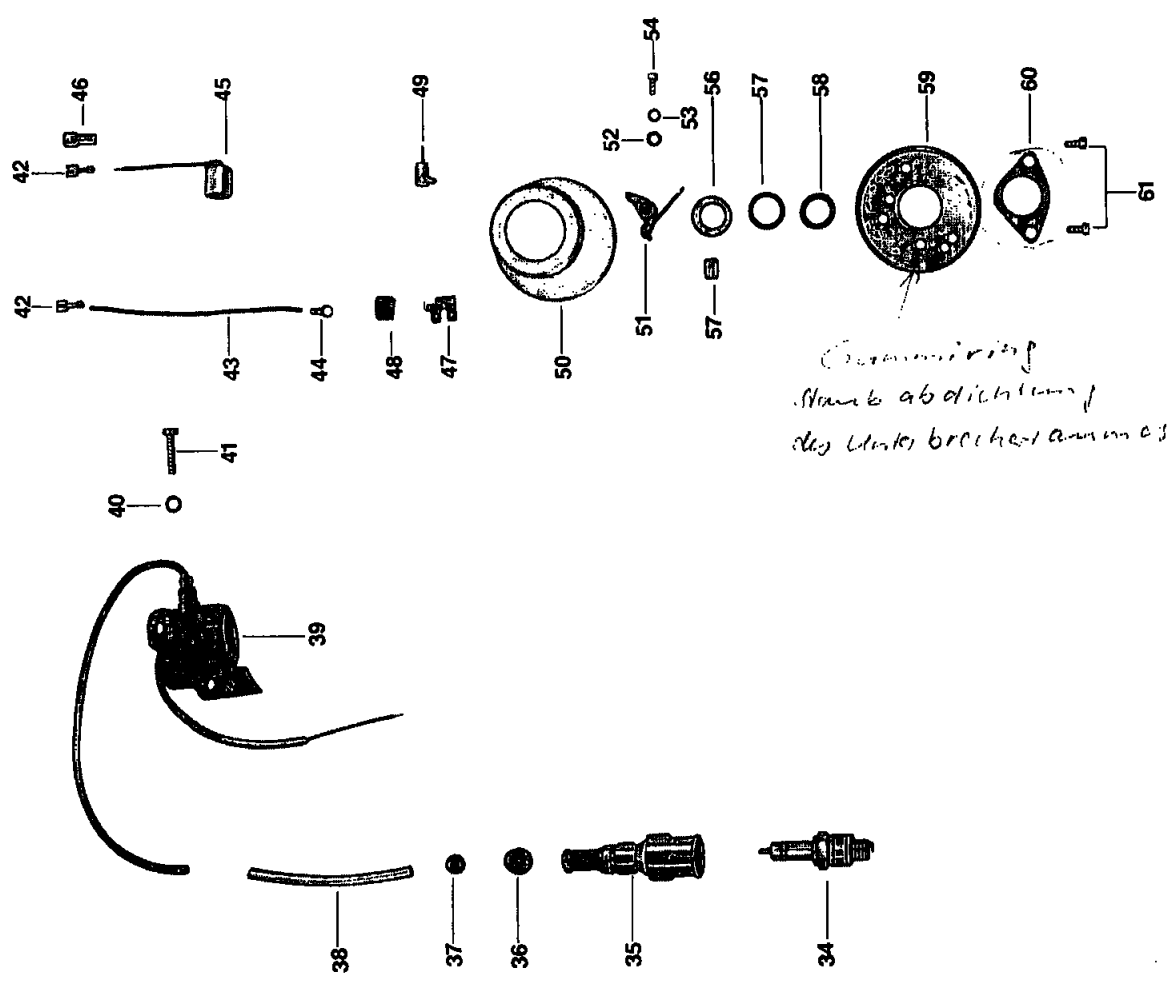
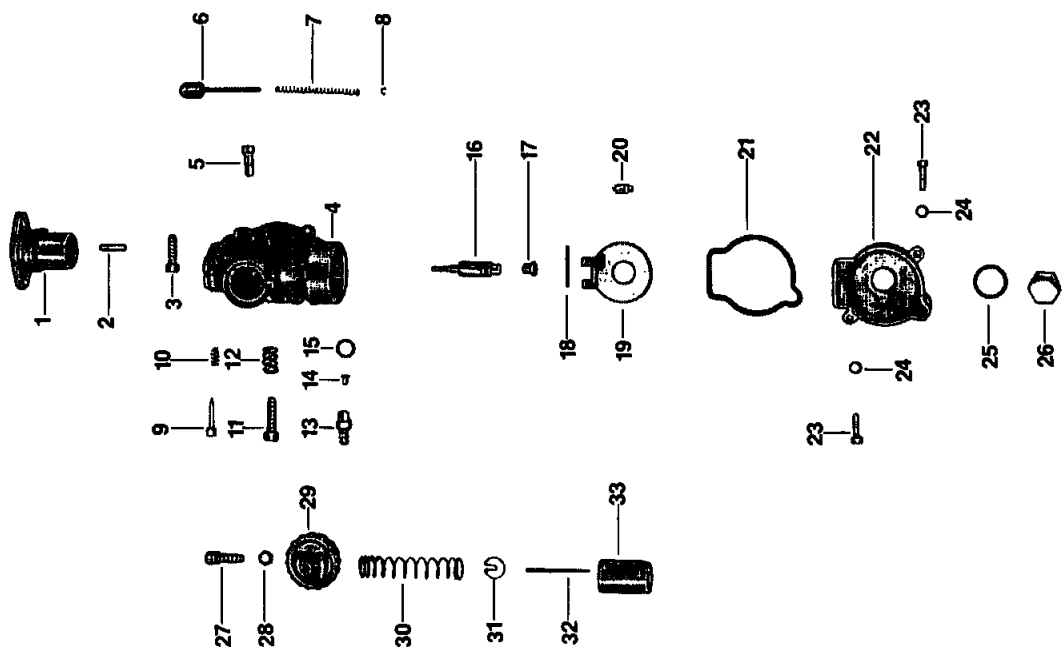

*Sammlung
Stark abdichtung
des Unterbracketansatzes*

Bild-Nr.	Anz.	Teilbezeichnung	Sachnummer	Bestell- u. Lager-Nr.
51	1	Unterbrecher	000.43-05.865	53-371
52	1	Scheibe 4,3 DIN 125	12310-01-7	05-371
53	2	Federring B 4 DIN 127	12505-02-0	15-424
54	1	Schraube AM 4x10 DIN 84	11105-01-2	13-236
55	1	Schmierfilz	000.43-06.313	53-372
56	1	Nocken	000.43-05.730	53-373
57	1	Federscheibe	079.11-001-00	53-374
58	1	Anlagescheibe	079.11-008-00	53-375
59	1	Grundplatte	079.11-013-10	53-487
60	1	Dichtung	079.11-015-10	53-378
61	2	Schraube AM 4x10 DIN 84	11105-01-2	13-236
--	1	Anschlußschraube	077.11.809-01	53-486
zu 59	1	Gummring	079.50:406-00	55-591
		<u>Spezialwerkzeuge</u>		
	1	Abzieher	44431-807-00	43-075
	1	Haltering	44431-065-00	53-380
	1	Halbschalenpaar für Kugellager 47 Ø	44431-067-00	53-381
	1	Halbschalenpaar für Kugellager 42 Ø	44431-449-00	53-382
	1	Abzieher für Lüfterrad	44431-881-00	53-383
	1	Halterschlüssel für Mitnehmertopf	44431-675-00	53-384

1 Satz Stambabdichtung Unterbrecher

27-023

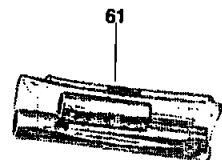
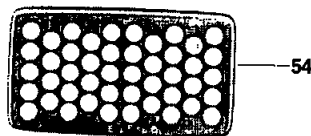
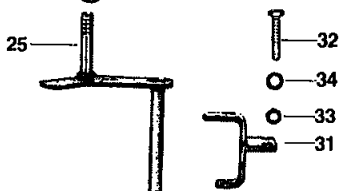
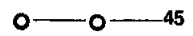
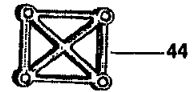
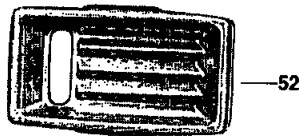
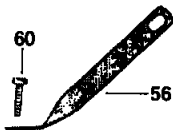
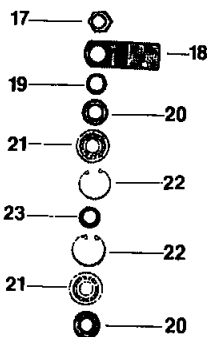
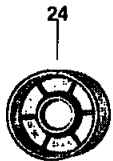
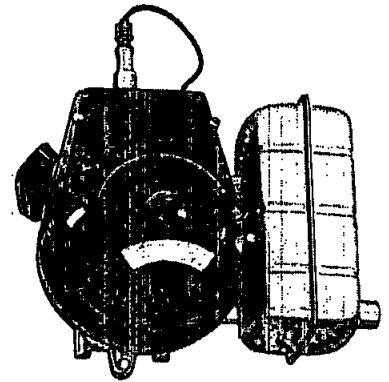
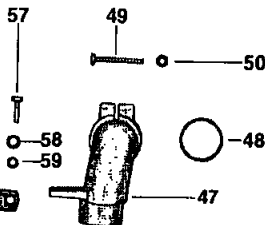
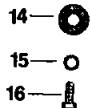
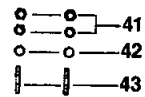
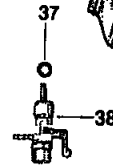
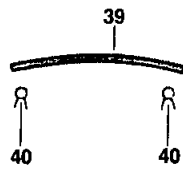
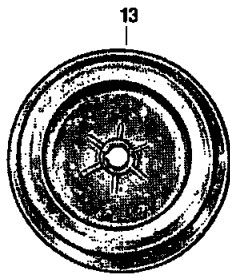
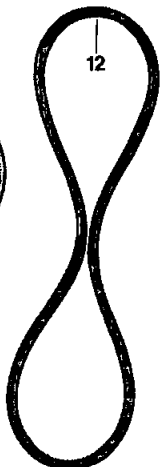
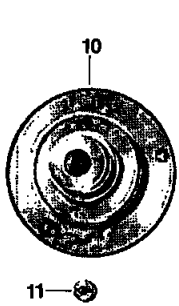
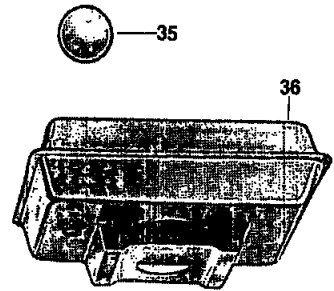
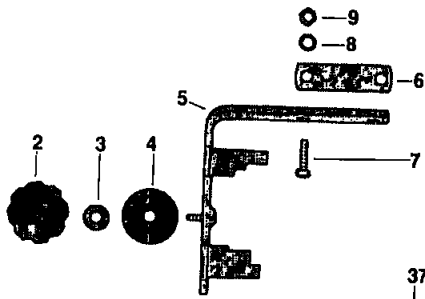
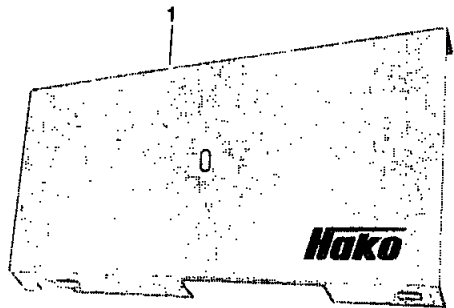

Keilriemenscheiben, Spannrolle, Motorzubehör

Bild-Nr.	Anz.	Teilbezeichnung	Sachnummer	Best.- u. Lager-Nr.
1	1	Schutzhaube	90-05954-4	34-044
	2	Verschlußstopfen F2	15590-07-8	10-627
	1	HAKO-Firmenzeichen schwarz	17200-02-3	53-480
2	1	Handrad 56/M 8	17133-01-8	48-043
3	1	Scheibe 8,4 DIN 9021	12332-02-9	04-290
4	1	Scheibe	90-00361-7	05-167
5	1	Halter	96-01131-7	49-033
6	1	Lasche	90-07163-0	53-477
7	2	Schraube M 8x30 DIN 933	11038-25-4	05-311
8	2	Federring B 8 DIN 127	12505-05-3	05-341
9	2	Mutter M 8 DIN 934	12022-05-9	05-335
10	1	Stufenscheibe	90-05808-2	49-026
11	1	Schlitzmutter	90-01830-0	15-456
12	1	Keilriemen 13x950 DIN 2215	16414-24-5	17-029
13	1	Stufenscheibe	90-05867-8	49-028
14	1	Scheibe R 9,5 DIN 440	12347-04-3	02-707
15	1	Federring B 8 DIN 127	12505-05-3	05-341
16	1	Schraube M 8x20 DIN 933	11038-21-3	05-309
17	1	Mutter M 12 DIN 985	12040-07-7	05-149
18	1	Riemenführung	90-01292-3	15-260
19	1	Distanzrohr, kurz	90-00373-2	15-331
20	2	Nilosring 6001 AV	14678-01-5	15-328
21	2	Lager 6001 DIN 605	14110-01-9	05-211
22	2	Sicherungsring 28x1,2 DIN 472	12660-02-3	12-117
23	1	Distanzrohr	90-00372-4	15-330
24	1	Spannrolle	90-00370-8	42-007
25	1	Spannhebel	96-01118-4	49-025
26	1	Buchse	90-03753-2	29-032
27	2	Paßscheibe 12x18x1 DIN 988	12-335-18-8	04-672
28	1	Drehfeder	90-03754-0	29-025
29	1	Hebel	90-05545-0	04-757
30	1	Spiralstift S 4x20	13053-02-0	10-260
31	1	Halter	96-01132-5	49-029
32	2	Schraube M 8x22 DIN 933	11038-23-9	07-711
33	2	Mutter M 8 DIN 985	12040-05-1	05-151
34	2	Scheibe 8,4 DIN 125	12310-04-1	05-375
35	1	Bajonett-Verschluß B 30	90-05630-0	04-432
36	1	Tank	96-01066-5	35-009
	1	HAKO-Firmenzeichen	17200-01-5	53-479
37	1	Dichtring H 1/3.140	90-00324-5	02-249
38	1	Doppelfilter-Einweghahn	90-00322-0	06-007
39	1	Benzinschlauch 5x9x160 lg.	27670-01-7	07-727
40	2	Schlauchklemme A-5,5	17527-01-7	04-196
41	4	Mutter M 5 DIN 934	12022-03-4	05-332
42	4	Federring B 5 DIN 125	12505-03-8	05-417
43	4	Stiftschraube M 5x15 DIN 835	11364-02-3	53-388
44	1	Motorsockel	90-05826-4	49-027
45	4	Federring B 8 DIN 127	12505-05-3	05-341
zu 32	1	Schraube M8x40 DIN 933	11038-27-0	73-370

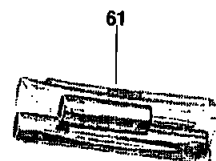
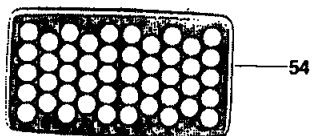
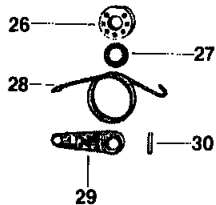
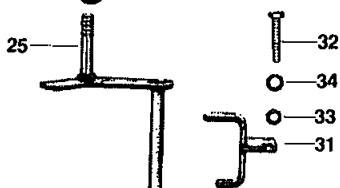
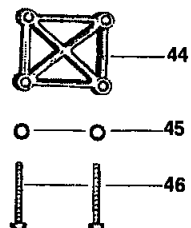
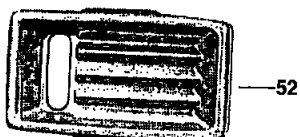
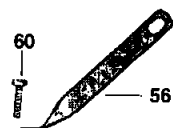
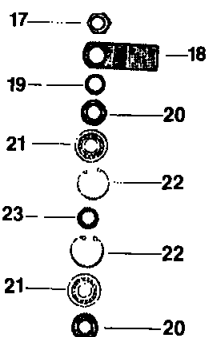
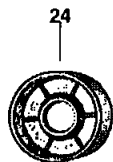
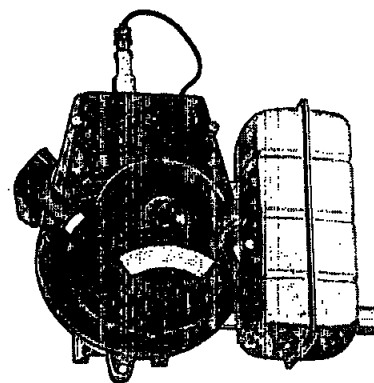
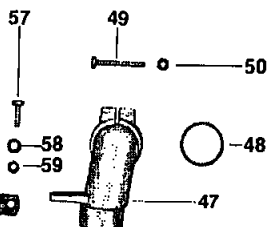
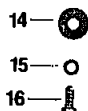
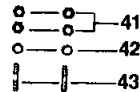
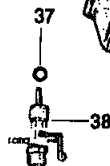
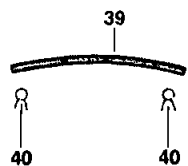
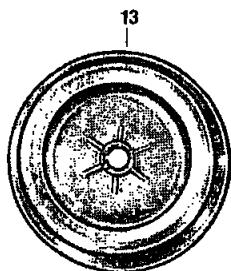
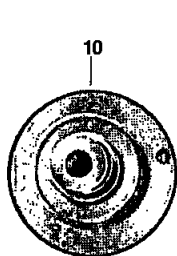
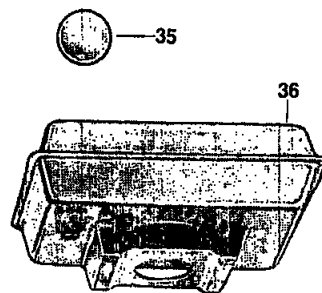
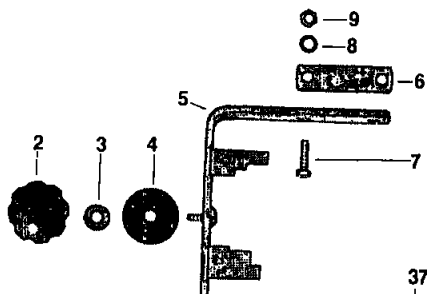
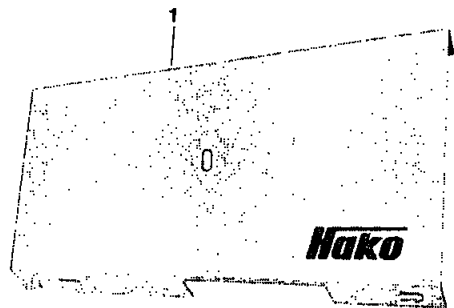

Keilriemenscheiben, Spannrolle, Motorzubehör

Bild-Nr.	Anz.	Teilbezeichnung	Sachnummer	Best.- u. Lager-Nr.
		50 835	11364-74-8	53-558
46	4	Schraube M 8x55 DIN 933	11038-30-4	05-313
47	1	Ansaugstutzen	90-05724-1	49-006
48	1	O Ring 35x2,5	15286-50-3	53-446
49	1	Schraube M 6x45 DIN 931	11032-09-1	10-686
50	1	Mutter M 6 DIN 985	12040-04-4	05-152
51	1	Schelle S 45x9 Zy	17528-13-4	07-714
52	1	Gehäuse	90-04264-9	21-060
53	1	Einatz	90-04262-3	21-061
54	1	Deckel	90-04263-1	21-062
55	1	Lasche	90-07162-2	53-474
56	1	Lasche	90-07143-2	53-473
57	1	Schraube M 6x20 DIN 933	11038-09-8	05-302
58	1	Federring B 6 DIN 127	12505-04-6	05-340
59	1	Mutter M 6 DIN 934	12022-04-2	05-333
60	1	Schraube M 6x25 DIN 933	11038-11-4	05-303
61	1	Zündkerzenschlüssel SW 21x80	35-34-0001	19-020
61	1	Steckschlüssel B 19x22 DIN 896	35-33-0100	46-023
61	1	Drehstift A 8 DIN 900	35-37-0901	04-374
2446	4	Mutter MP DIN 934	12022-05-9	05-335
	1	Ölbadluftfilter	90-05279-6	01-051
	1	Krümmmer	90-05762-4	21-139
	1	Halter	96-01491-5	45-111
	1	Schlauchschelle 45/9 Zy	17528-13-4	07-714
	1	Schlauchschelle 40/9 Zy	17528-20-9	04-195
	1	Spannschelle 100/20 SKZ	17528-27-4	45-112
67	1	Steckschlüssel SW 21x170 DIN 659	35-33-0005	27-020

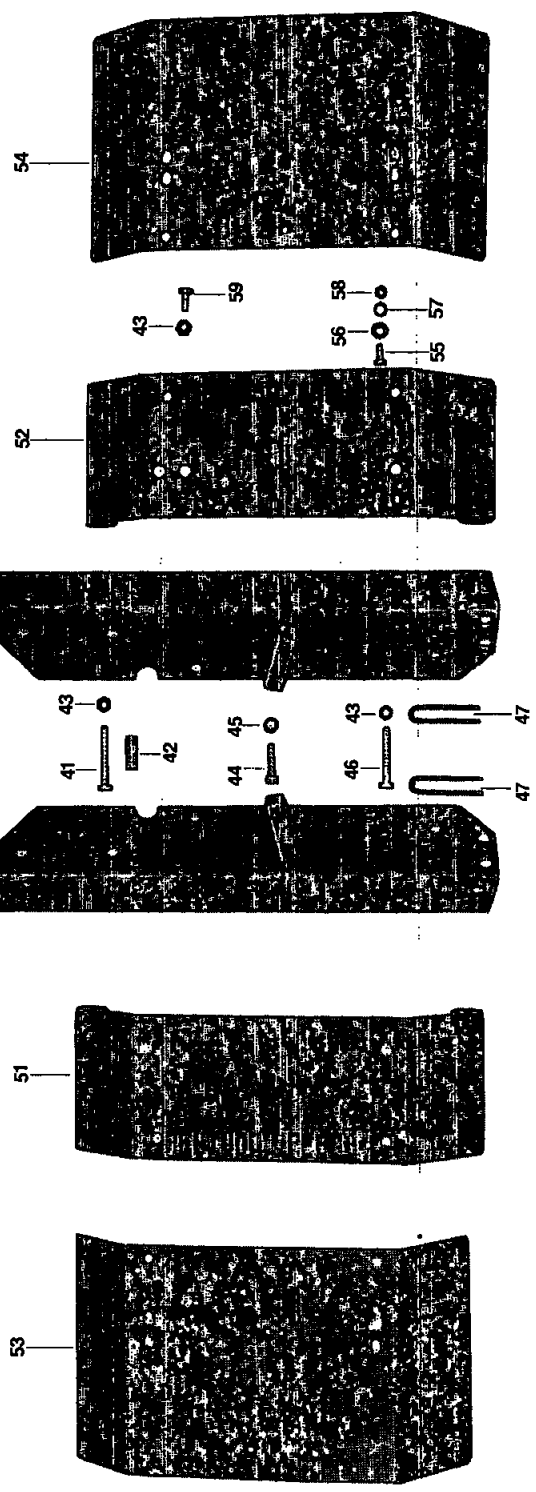
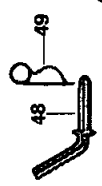
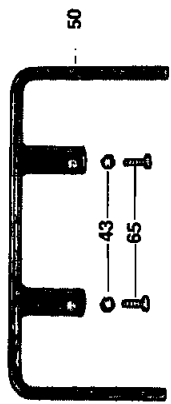
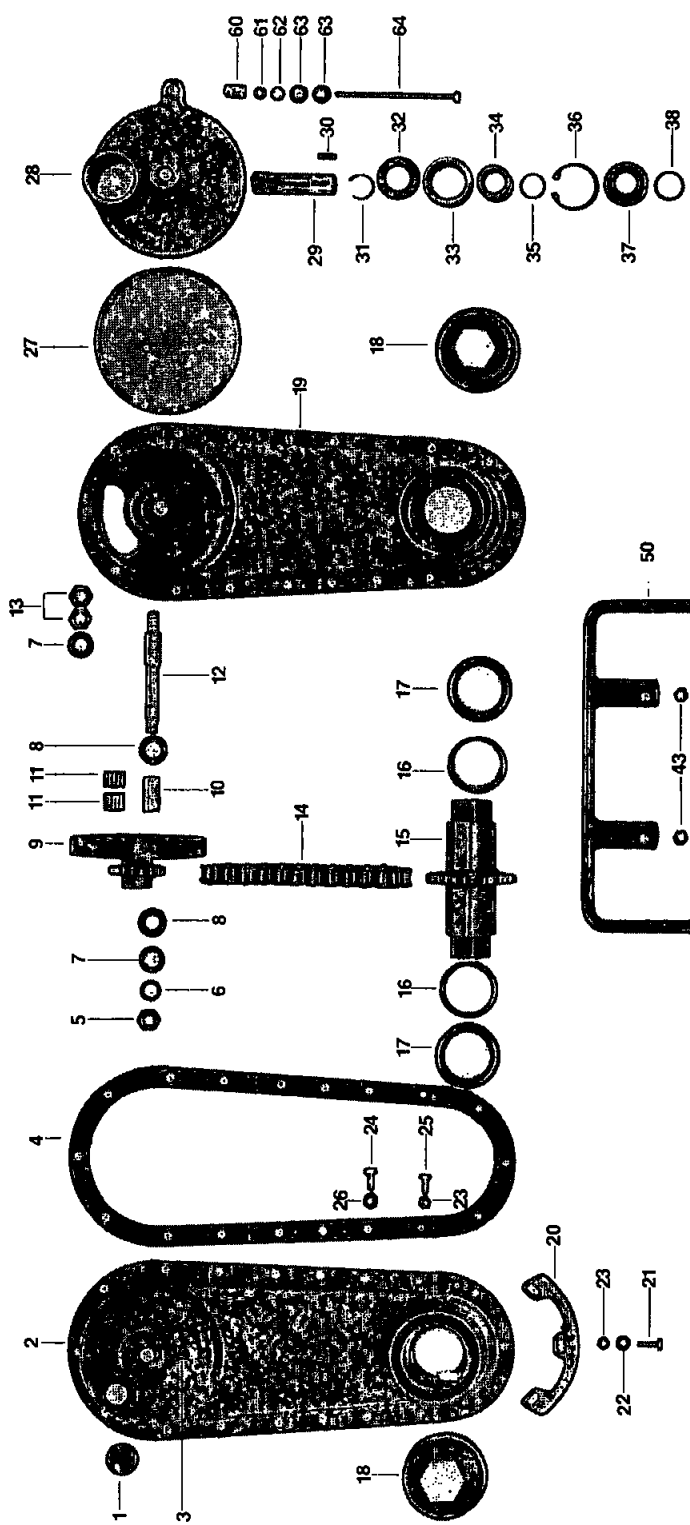

Getriebe, Schutzblech, Träger

Bild-Nr.	Anz.	Teilbezeichnung	Sachnummer	Best.- u. Lager-Nr.
1	1	Gummistopfen 04107	90-00434-2	15-440
2	1	Gehäusehälfte re.	96-00082-3	01-004
3	1	Ölstandsschild	90-00926-7	02-493
4	1	Dichtung	90-00456-5	44-002
5	1	Mutter M 12 DIN 934	12022-07-5	05-337
6	1	Federring B 12 DIN 127	12505-07-9	05-343
7	2	Scheibe 13 DIN 125	12310-06-6	05-377
8	2	Anlagescheibe	90-00404-5	13-525
9	1	Innenzahnrad	90-01844-1	44-006
10	1	Lagerhülse	90-01841-7	15-449
11	2	Nadelhülse K 16/17	14673-05-7	15-303
12	1	Lagerachse	90-01842-5	15-442
13	2	Mutter M 12 DIN 936	12015-01-2	02-527
14	1	Kette 1x15,875 x 9,65 x 46 DIN 8187 endlos	16365-04-1	44-007
15	1	Werkzeugwelle	96-00067-4	44-008
16	2	Nadelhülse HK 4520	14674-02-2	08-046
17	2	Wellendichtring	90-04585-7	08-060
18	2	Schutzkappe	90-00430-0	17-049
19	1	Gehäusehälfte li.	96-00081-5	01-008
20	1	Schleifschutz	90-01839-1	44-042
21	3	Schraube M 6x20 DIN 933	11038-09-8	05-302
22	3	Scheibe 6,4 DIN 125	12310-03-3	05-373
23	5	Mutter M 6 DIN 985	12040-04-4	05-152
24	3	Schraube M 8x15 DIN 933	11038-19-7	05-308
25	2	Schraube M 6x15 DIN 933	11038-07-2	05-301
26	3	Mutter M 8 DIN 985	12040-05-1	05-151
27	1	Dichtring	90-01843-3	44-012
28	1	Schwenklager	90-00455-7	44-011
29	1	Ritzel	90-04917-2	04-751
30	1	Paßfeder A 6x6x18 DIN 6885	13540-11-7	02-207
31	1	Seeger-V-Ring A 20x1,2	12626-01-6	15-386
32	1	Scheibe	90-04920-6	04-754
33	1	Nadelkäfig 32/20 A	14231-01-3	04-752
34	1	Lauftring	90-04916-4	04-753
35	1	O-Ring 20x2	15286-10-7	15-509
36	1	Sicherungsring 42x1,75 DIN 472	12660-05-6	15-444
37	1	Kugellager 6004 2RS DIN 625	14110-37-3	04-625
38	1	Paßscheibe 20x28x1 DIN 988	12335-17-0	15-370
39	1	Träger li.	96-00973-3	34-045
	1	Typenschild	90-04655-8	53-481
	2	Kerbnagel 3x4 DIN 1476	13250-03-0	53-433
40	1	Träger re.	96-01040-0	34-046
41	1	Schraube M 8x55 DIN 933	11038-30-4	05-313
42	1	Distanzrohr	90-05257-2	04-756
43	8	Mutter M 8 DIN 985	12040-05-1	05-151
44	1	Schraube M 8x25 DIN 7984	11132-05-7	10-279
45	1	Federring 8 DIN 7980	12507-01-8	15-704

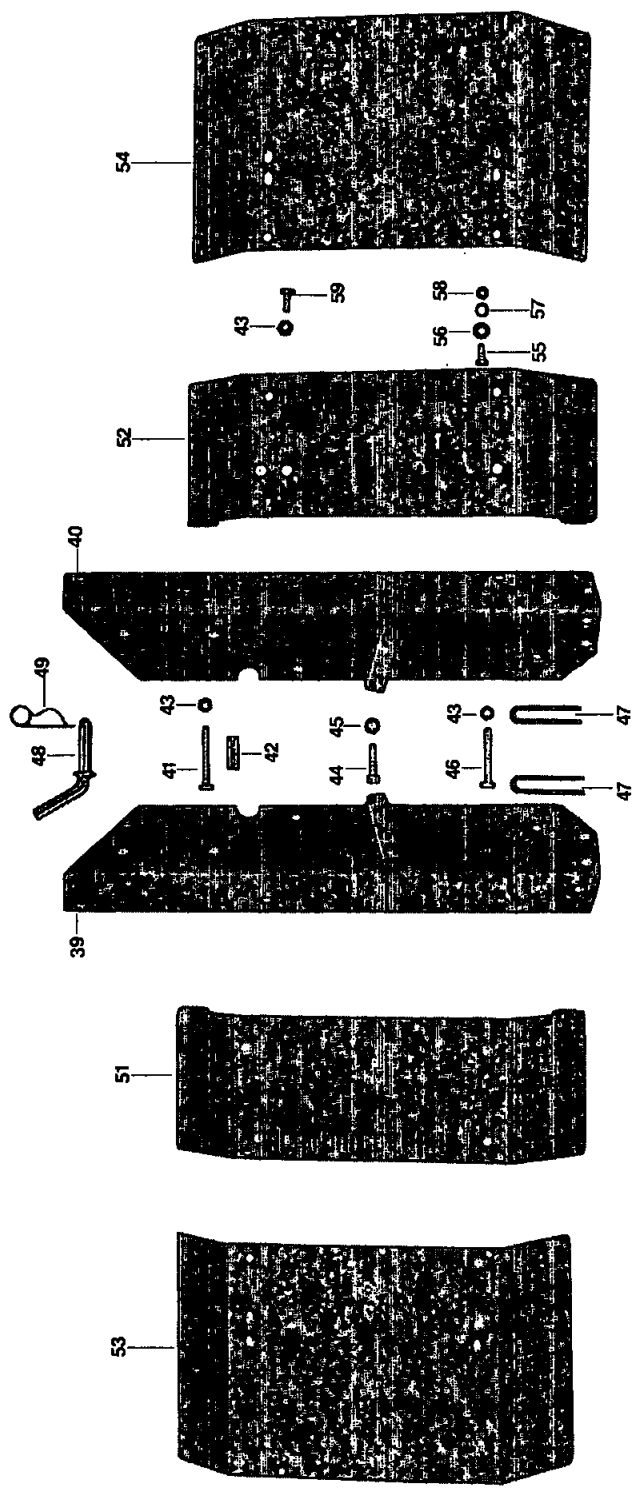
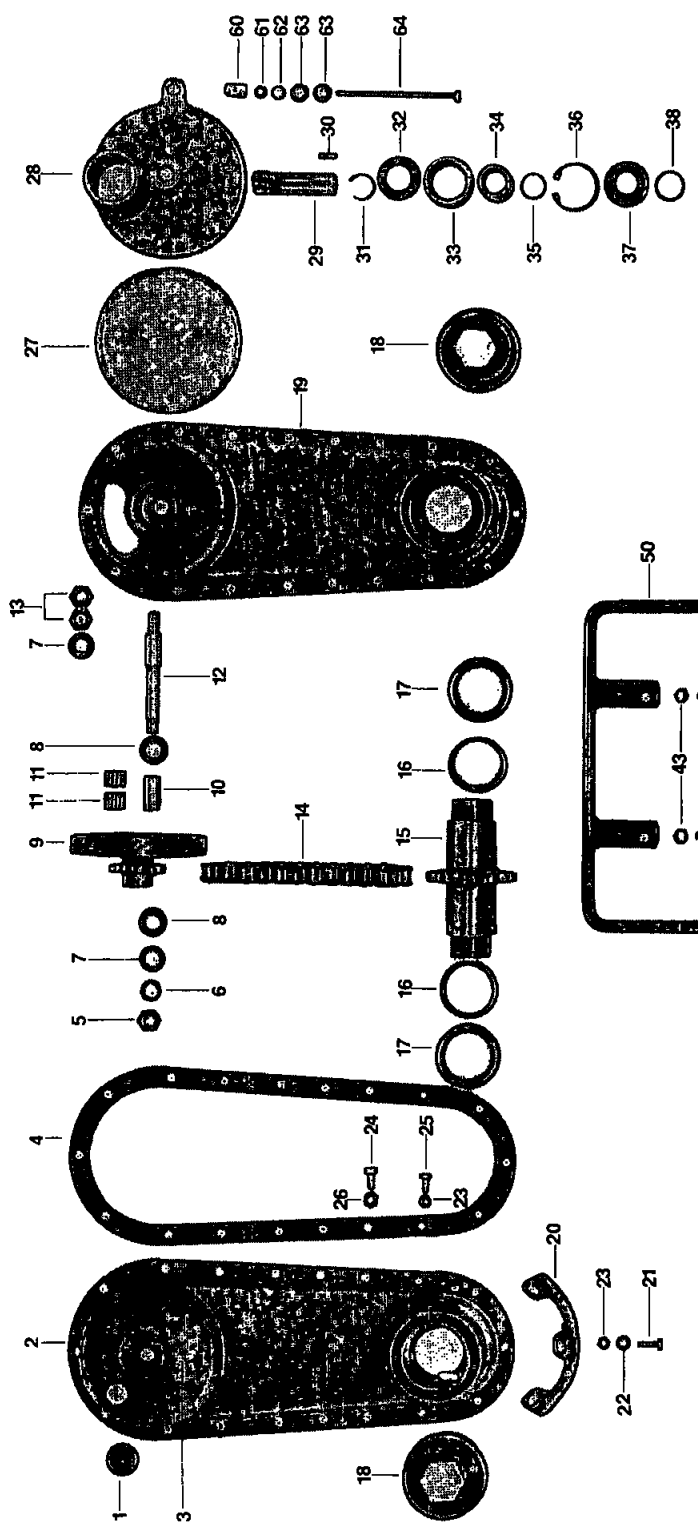

Getriebe, Schutzblech, Träger

Bild-Nr.	Anz.	Teilbezeichnung	Sachnummer	Best.- u. Lager-Nr.
46	3	Schraube M 8x50 DIN 933	11038-29-6	05-326
47	2	Abstandsbügel	90-01836-7	15-459
48	1	Vorstecker	96-00980-8	39-060
49	1	Federvorstecker	90-00459-9	14-015 ✓
50	1	Griff	96-01150-7	49-032
51	1	Schutzblech li.	96-01130-9	34-042
	2	Aufkleber "Achtung Gefahr"	90-05347-1	53-482
52	1	Schutzblech re.	96-00378-5	34-043
53	1	Schutzblech li.	90-05280-4	32-061
54	1	Schutzblech re.	90-05558-3	32-062
55	4	Schraube M 6x15 DIN 933	11038-07-2	05-301
56	4	Scheibe B6,4 DIN 9021	12332-01-1	13-512
57	4	Federring B 6 DIN 127	12505-04-6	05-340
58	4	Mutter M 6 DIN 934	12022-04-2	05-333
59	7	Schraube M 8x15 DIN 933	11038-19-7	05-308
60	1	Gewindekloben	90-01803-7	15-445
61	1	Mutter M 6 DIN 934	12022-04-2	05-333
62	1	Federring B 6 DIN 127	12505-04-6	05-340
63	2	Scheibe B 6,4 DIN 9021	12332-01-1	13-512
64	1	Schraube	96-01189-5	53-475
65	2	Schraube M 8x ²⁰ 25 DIN 933	11038-24-7	05-310
			21-3	05-309
	1	Typenschild	17210-01-4	53-481
	2	Aufkleber	17250-01-0	53-482
	1	Aufkleber	17209-01-6	53-606
	1	Aufkleber	17256-01-7	53-437
	1	Aufkleber Luftfilter	17261-01-7	55-587
	1	Aufkleber Motor Öl	17261-02-5	55-588

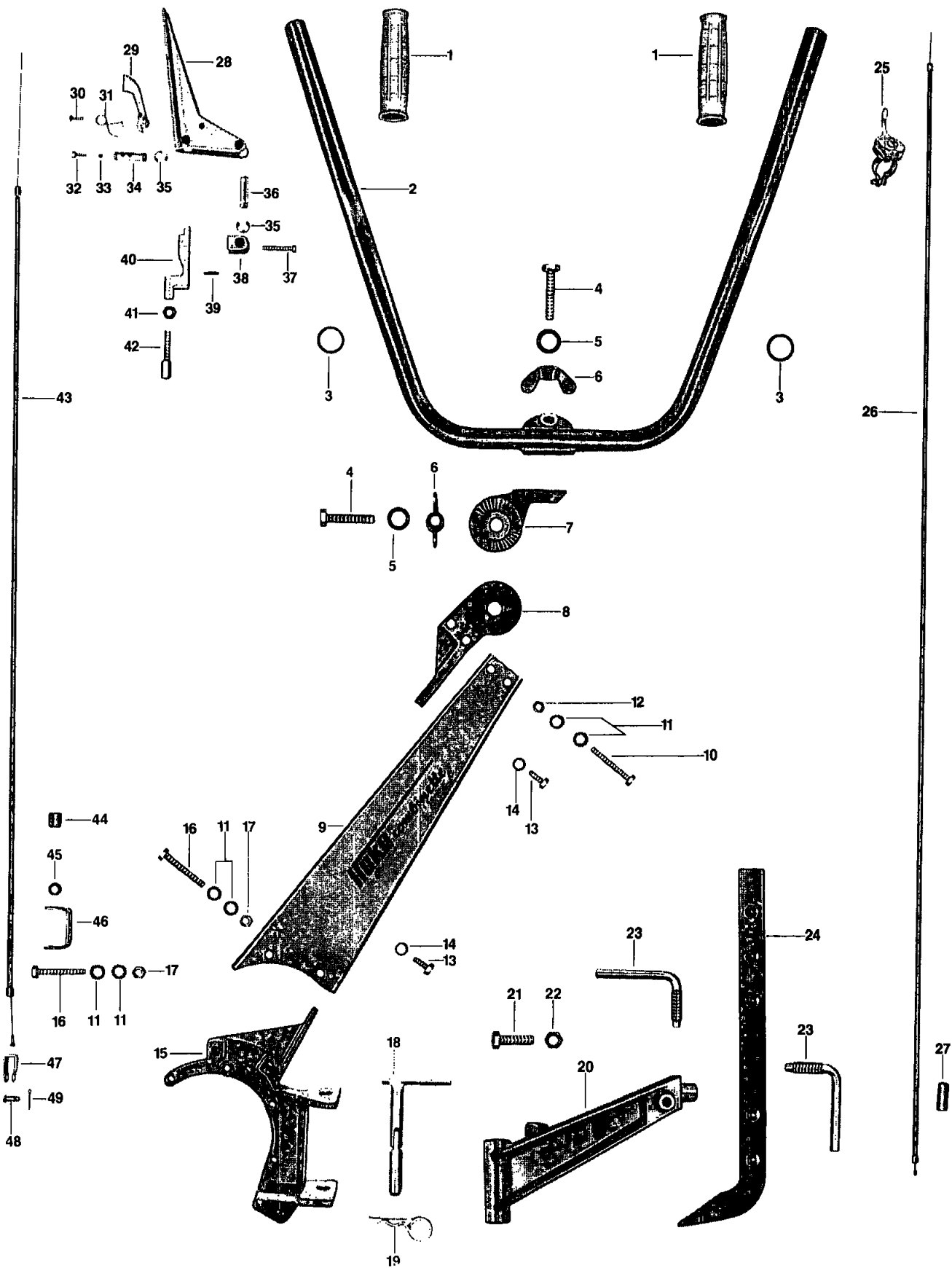

Holm, Spannrollenhebel, Bremssporn

Bild-Nr.	Anz.	Teilbezeichnung	Sachnummer	Best.- u. Lager-Nr.
1	2	Griff	90-00338-5	14-012
2	1	Griffrohr	96-01134-1	35-026
3	2	O-Ring 22x3,5	15286-19-8	15-612
4	2	Schraube M 12x55 DIN 933	11038-53-6	15-577
5	2	Scheibe 13 DIN 125	12310-06-6	05-377
6	2	Flügelmutter M 12 DIN 315	12158-05-1	12-211
7	1	Zwischenstück	90-05831-4	49-030
8	1	Holmkopf	90-05832-2	49-031
9	1	Holm	90-05155-8	33-014
	2	Namenszug Combinette	17205-04-8	53-478
10	2	Schraube M 8x55 DIN 933	11038-30-4	05-313
11	4	Scheibe 8,4 DIN 125	12310-04-1	05-375
12	2	Mutter M 8 DIN 934	12022-05-9	05-335
13	2	Schraube M 8x15 DIN 933	11038-19-7	05-308
14	2	Federring B 8 DIN 127	12505-05-3	05-341
15	1	Anhängebock	90-05866-0	49-035
16	2	Schraube M 8x55 DIN 933	11038-30-4	05-313
17	2	Mutter M 8 DIN 985	12040-05-1	05-151
18	1	Gelenkbolzen	97-00475-8	49-034
19	1	Vorstecker	90-00126-4	05-286
20	1	Bremsspornhalter	90-01092-7	44-038
21	2	Schraube M 12x40 DIN 933	11038-49-4	05-322
22	2	Mutter M 12 DIN 934	12022-07-5	05-337
23	2	Gewindehebel	90-05240-8	39-061
24	1	Bremssporn	90-01223-8	30-035
25	1	Regulierhebel H 14a R/25zK	90-00340-1	07-303
26	1	Bowdenzug	96-00281-1	24-002
27	1	Gummitülle	90-00334-4	07-308
28	1	Handhebel	90-03256-6	21-002
29	1	Rasthebel	90-03255-8	07-603
30	2	Halbrundkerbnagel 4x15 SIN 1476	13250-06-3	07-602
31	1	Biegefeder	90-03259-0	07-601
32	1	Schraube M 5x12 DIN 933	11038-03-1	15-280
33	1	Kugel 35 mm Kl.V DIN 5401	14620-03-3	07-605
34	1	Bolzen	90-04320-9	07-606
35	4	Sicherungsscheibe 8 DIN 6789	12640-03-3	04-628
36	1	Bolzen	90-03263-2	07-604
37	1	Schraube AM 6x35 DIN 84	11105-10-3	07-609
38	1	Gelenkstück	90-03258-2	07-608
39	1	Spiralstift S 3x16	13053-01-2	07-329
40	1	Kulisse	90-05118-6	39-053
41	1	Mutter BM 8 DIN 439	12012-01-9	04-650
42	1	Stellschraube M 8	90-00333-6	07-429
43	1	Bowdenzug	96-00287-8	24-04724-023
44	1	Schlauch A 9x14 DIN 73379 15 lg.	27670-03-3	53-476
45	1	Kabelmuffe 470 0026	15595-03-6	53-429
46	1	Widerlager	90-05748-0	53-430
47	1	Zugbügel	90-00335-1	13-318
48	1	Bolzen 6h 11x16x12 DIN 1434	13328-01-8	13-320
49	1	Splint 1,5x20 DIN 94	13280-03-7	05-187

